

AL  
SL  
O

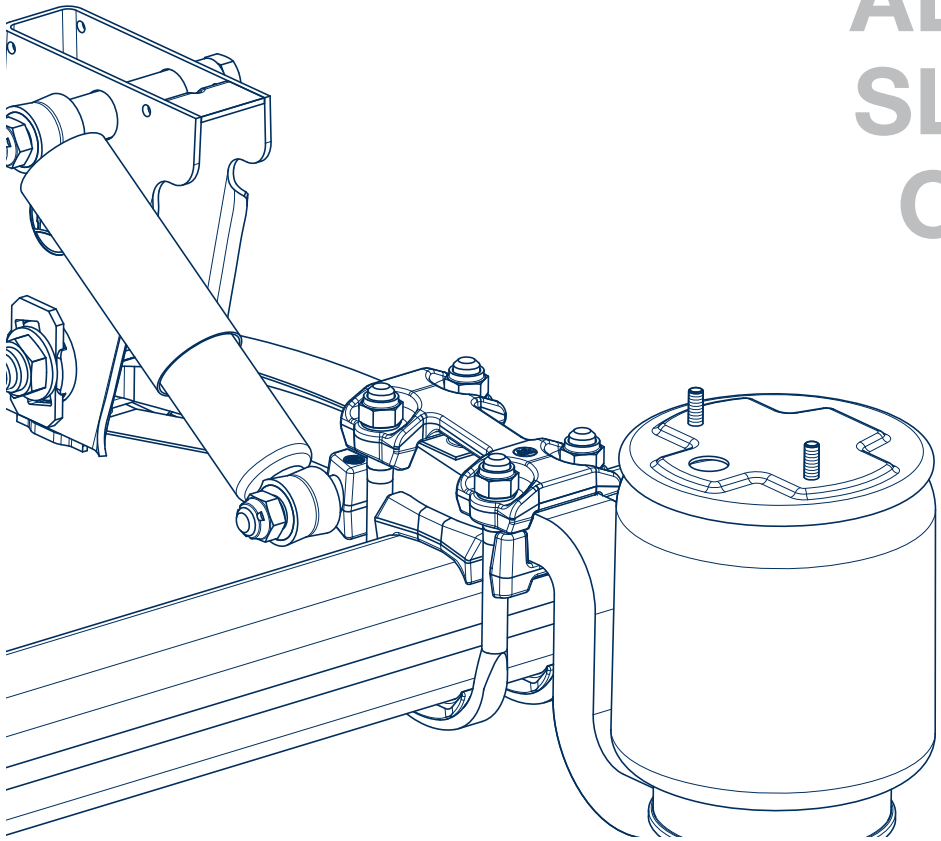

# Workshop manual

BPW air suspensions, series AL / SL / O



# Contents

◎ <b>1. Product identification</b>	<b>Page 4</b>
1.1 Explanation of BPW axle type codes (extract)	Page 4
1.2 Explanation of BPW code numbers (extract)	Page 6
◎ <b>2. Special tools</b>	<b>Page 8</b>
◎ <b>3. Exploded view / name</b>	<b>Page 10</b>
◎ <b>4. Tightening torques</b>	<b>Page 15</b>
◎ <b>5. Safety regulations, safety information</b>	<b>Page 16</b>
5.1 Safety regulations	Page 16
5.2 Safety information	Page 17
◎ <b>6. Care and maintenance</b>	<b>Page 18</b>
◎ <b>7. Dismantling and assembly of axle and trailing arms</b>	<b>Page 32</b>
◎ <b>8. Dismantling and assembly of trailing arm</b>	<b>Page 42</b>
8.1 Dismantling trailing arm	Page 42
8.2 Fit trailing arm springs	Page 44
8.2.1 Fit trailing arm springs (air suspension overslung)	Page 46
8.2.2 Fit trailing arm springs (air suspension underslung)	Page 49
8.3 Fit trailing arm springs (air suspension overslung and underslung)	Page 53
8.4 Change steel / rubber / steel bushes	Page 56
◎ <b>9. Dismantling and assembly of U-stabiliser</b>	<b>Page 57</b>
9.1 Dismantling of U-stabiliser	Page 57
9.2 Installation of U-stabiliser	Page 59
◎ <b>10. Dismantling and assembly of air bags</b>	<b>Page 61</b>
10.1 Dismantling of air bags	Page 61
10.2 Assembly of air bags	Page 63
10.3 Dismantling of air bags, assembling - Air bag with universal plate	Page 65
10.4 Dismantling of air bags, assembling - Air bag with central bolt connection	Page 66
10.5 Dismantling of air bags, assembling - Air bag with steel piston	Page 67
10.6 Dismantling of air bags, assembling - Combi Air bag	Page 68
10.7 Dismantling of air bags, assembling - Airlight Direct	Page 69
◎ <b>11. Dismantling and assembly of shock absorbers</b>	<b>Page 70</b>
◎ <b>12. Detaching and attaching check straps</b>	<b>Page 73</b>
◎ <b>13. Dismantling and assembly of axle lift device</b>	<b>Page 74</b>
13.1 Lateral and central axle lift device	Page 74
13.2 Double-sided axle lift with adjustable hanger, trailing arm 70 mm wide	Page 80
13.3 Double-sided axle lift with fixed and adjustable hanger, trailing arm 100 mm wide	Page 84
13.4 Double-sided axle lift with adjustable, bolted hanger – SLO / SLM series	Page 89
◎ <b>14. Air levelling valve</b>	<b>Page 94</b>
◎ <b>15. Shut-off valve</b>	<b>Page 96</b>
◎ <b>16. Axle alignment check</b>	<b>Page 97</b>
16.1 Conventional axle alignment on the vehicle	Page 97
16.2 Axle alignment check with laser measuring devices	Page 102
◎ <b>17. Other inspection operations</b>	<b>Page 103</b>

- Refer to appropriate workshop manuals for axle repairs

# 1 Product identification

## 1.1 Explanation of BPW axle type codes (extract)

Example

H	S	F	H	SLO	A	LL	3/	9010	/12°	A	F30	ECO			
														<b>Axle series</b>	<b>Brake</b>
H														H..	SN 420
K														K..	SN 360
N														N..	SN 300
SH														SH..	SB 4309 /SB 4345; TSB 4309 / TSB 4312
SK														SK	SB 3745; TSB 3709
B														For single wheels, wheels with off set	
S														For single wheels, wheels without off set	
Z														For twin wheels	
I														Wheel spiders for TRILEX wheel rims, single wheels	
IZ														Wheel spiders for TRILEX wheel rims, twin wheels	
F														Wheel studs M 22 x 1.5 without wheel nuts, order wheel nuts for stud or spigot alignment separately	
M														For spigot alignment / Aluminium wheel connection	
H														For hanging boosters	
														<b>Air suspension series</b>	<b>Ride height</b>
														O	O = straight overslung trailing arm 490 - 500
														OM	OM = cranked overslung trailing arm 370 - 470
														OMN	OMN = cranked overslung trailing arm 355
														OMT	OMT = cranked underslung trailing arm 290
														OT	OT = underslung trailing arm 220 - 330
														SLO	SLO = straight overslung trailing arm 420 - 490
														SLM	SLM = cranked overslung trailing arm 360 - 440
														SLU	SLU = underslung trailing arm 220 - 330
														ALO	ALO = straight overslung trailing arm 380 - 490
														ALM	ALM = cranked overslung trailing arm 305 - 420
														ALMT	ALMT = cranked overslung trailing arm 245 - 290
														ALU	ALU = underslung trailing arm 175 - 300
														DLU	DLU = Airlight Direct 260 - 330
														A	With axle lift device
														R	With frame (= ride height + 100 mm)
														U	With U-stabiliser
														L	With steering axle, series L - steering angle max. 40°
														LL	With self-steering axle, series LL - steering angle max. 20°

Example

H	S	F	H	SLO	A	LL	3/	9010	/12°	A	F30	ECO			
								-							Single axle
								2 /							Tandem axle suspension
								3 /							Tri-axle suspension
								6006 to 13010							Axle load (kg) + quantity of wheel studs per hub
									/12° to /40°						Steering angle of steering axle
										A					Alloy hanger brackets
										C					Integrated support
										D					Hanger brackets with top plate
										E					Hanger brackets without top plate
										G					Air bags with split piston
										K					Bolted on hanger brackets
										S					Taper mounted hanger brackets (70 mm wide)
										T					With support (trailing axle)
										V					Adjustable hanger brackets
										X					With stainless steel hanger brackets
										Y					Without mounted hanger brackets, hanger brackets separate
											30				Air bag Ø 300 mm, for stroke 200 mm (standard)
											30-1				Air bag Ø 300 mm, for stroke up to 340 mm
											30 K				Air bag Ø 300 mm, for stroke 150 mm
											36				Air bag Ø 360 mm, for stroke 200 mm (standard)
											36-1				Air bag Ø 360 mm, for stroke up to 340 mm
											36-2				Air bag Ø 360 mm, for stroke up to 450 mm
											36 K				Air bag Ø 360 mm, for stroke 180 mm
											F30				Air bag Ø 300 mm, central on the trailing arm
											Z				Without mounted air bags, air bags separate
												ECO Plus 3			Weight optimised trailer axle with ECO Plus 3 Unit
												ECO Plus 2			Weight optimised trailer axle with ECO Plus 2 Unit
												ECO <sup>Plus</sup>			Weight optimised trailer axle with ECO <sup>Plus</sup> Unit
												ECO			Trailer axle with ECO Unit
												ECO-MAXX			Weight optimised trailer axle with ECO Unit
												MAXX			Weight optimised trailer axle with helical fit wheel bolts

# 1 Product identification

## 1.2 Explanation of BPW axle code numbers (extract)

Example:

61.	38.	441.	001
<b>1. + 2. digit</b>			
21. 28. 30.		Air suspension single axle	
38.		Air suspension single axle without air bags, air bags loose, separate	
61. 64. 67.		Air suspension single axle	
22.		Tandem axle air suspension	
32.		Tandem axle air suspension / tri-axle air suspension	
62. 65. 68.		Tandem axle air suspension	
23. 29. 39.		Tri-axle air suspension	
63. 66. 69.		Tri-axle air suspension	
<b>3. + 4. digit: axle load and bearing</b>			
		<b>Axle load</b>	<b>Roller bearing</b>
			<b>Bearing generation</b>
06.		6500 kg	33116 / 32310
08.		8000 - 9000 kg	33116 / 32310
10.		10000 -12000 kg	33118 / 32313
14.		13000 - 14000 kg	32219 / 33215
36.		6500 kg	33116 / 32310
37.		8000 - 9000 kg	33116 / 32310
38.			
39.			
40.		10000 - 12000 kg	33118 / 32313
41.			
44.		13000 - 14000 kg	32219 / 33215
47.		8000 - 9000 kg	33118 / 32313
48.			
49.			
50.		10000 - 12000 kg	33118 / 32313
51.			
57.		8000 - 9000 kg	33118 / 32313
58.			
59.			
65.		6400 kg	32215 / 32310
68.		8000 - 9000 kg	33118 / 32313

Example:

61.	38.	441.	001
<b>5. - 7. digit</b>			
001. to 099		<b>Premounted air suspension axle without hanger brackets and air bags</b> in the case of ref. number 61.xx.xxx.xxx - 69.xx.xxx.xxx e.g.: .0xx. = Premounted air suspension axle .x51. = Premounted air suspension axle with trailing arm 05.082.13.51.0	
220. to 509		<b>Designation of ride height and air bag type 220 to 509</b> in the case of ref. number 61.xx.xxx.xxx - 69.xx.xxx.xxx e.g.: .22x. = 220 mm ride height .44x. = 440 mm ride height  Air bag type: .xx0. = BPW 30 (Ø 300 mm) .xx1. = BPW 36 (Ø 300 mm) .xx2. = BPW 36-1 (Ø 300 mm) .xx3. = BPW 30-1 (Ø 300 mm) .xx4. = BPW 30 K (Ø 300 mm) .xx5. = BPW 36 K (Ø 300 mm) .xx6. = BPW 36-2 (Ø 300 mm) .xx9. = BPW 30 / 36 loose separately	
501. to 509.		<b>Designation of wheel brake in the case of ref. number 20. - 39...</b> For explanations on the item number, refer to the corresponding axis	
<b>8. - 10. digit: consecutive number</b>			
000 to 999		Consecutive number 000 - 999	

## 2 Special tools

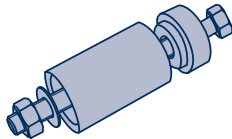
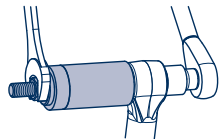
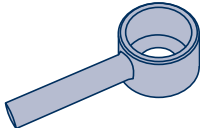
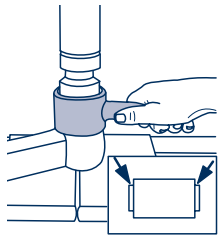
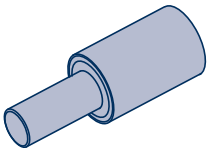
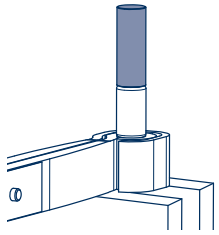
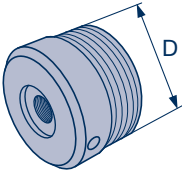
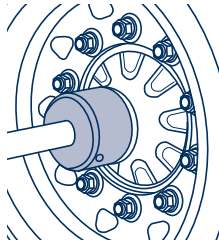
Number	Description	Illustration of tool	Tool in operation																											
1	<p>Assembly tool for removal and installation of rubber-steel bushes  <math>\varnothing</math> 50 - 60 mm</p> <p>BPW code number:  <b>14.825.11744</b></p>																													
2	<p>Press tool for installation of rubber-steel bushes in anti-roll bars (U-shaped)</p> <p>BPW code number:  <b>15.002.19433</b> <math>\varnothing</math> 52.6  <b>15.003.19433</b> <math>\varnothing</math> 60</p>																													
3	<p>Press tool for installation of steel-rubber-steel bushes</p> <p>BPW code number:  <b>03.084.37.10.0</b> <math>\varnothing</math> 30  <b>03.084.37.11.0</b> <math>\varnothing</math> 24</p>																													
4	<p>Threaded adapter for aligning axles and suspension units.</p> <p>BPW code number:</p> <p><b>Conventional hub bearing</b></p> <table border="0"> <tr> <td><b>15.013.01609</b></td> <td>M 115 x 2</td> <td>6.5 - 9 t</td> </tr> <tr> <td><b>15.014.01609</b></td> <td>M 125 x 2</td> <td>10 - 12 t</td> </tr> <tr> <td><b>15.012.01609</b></td> <td>M 135 x 3</td> <td>13 - 14 t</td> </tr> <tr> <td><b>16.008.01609</b></td> <td>M 155 x 3</td> <td>16 - 18 t</td> </tr> </table> <p><b>ECO Unit</b></p> <table border="0"> <tr> <td><b>15.020.01609</b></td> <td>M 125 x 2</td> <td>6.5 - 9 t</td> </tr> <tr> <td><b>15.021.01609</b></td> <td>M 135 x 2</td> <td>10 - 12 t (old)</td> </tr> <tr> <td><b>15.023.01609</b></td> <td>M 136 x 2.5</td> <td>10 t (new)</td> </tr> </table> <p><b>ECO Plus Unit</b></p> <table border="0"> <tr> <td><b>15.023.01609</b></td> <td>M 136 x 2.5</td> <td>8 - 12 t</td> </tr> </table> <p><b>ECO Plus 3 Unit</b></p> <table border="0"> <tr> <td><b>15.021.01609</b></td> <td>M 135 x 2</td> <td></td> </tr> </table>	<b>15.013.01609</b>	M 115 x 2	6.5 - 9 t	<b>15.014.01609</b>	M 125 x 2	10 - 12 t	<b>15.012.01609</b>	M 135 x 3	13 - 14 t	<b>16.008.01609</b>	M 155 x 3	16 - 18 t	<b>15.020.01609</b>	M 125 x 2	6.5 - 9 t	<b>15.021.01609</b>	M 135 x 2	10 - 12 t (old)	<b>15.023.01609</b>	M 136 x 2.5	10 t (new)	<b>15.023.01609</b>	M 136 x 2.5	8 - 12 t	<b>15.021.01609</b>	M 135 x 2			
<b>15.013.01609</b>	M 115 x 2	6.5 - 9 t																												
<b>15.014.01609</b>	M 125 x 2	10 - 12 t																												
<b>15.012.01609</b>	M 135 x 3	13 - 14 t																												
<b>16.008.01609</b>	M 155 x 3	16 - 18 t																												
<b>15.020.01609</b>	M 125 x 2	6.5 - 9 t																												
<b>15.021.01609</b>	M 135 x 2	10 - 12 t (old)																												
<b>15.023.01609</b>	M 136 x 2.5	10 t (new)																												
<b>15.023.01609</b>	M 136 x 2.5	8 - 12 t																												
<b>15.021.01609</b>	M 135 x 2																													

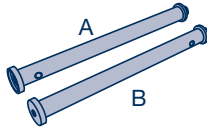
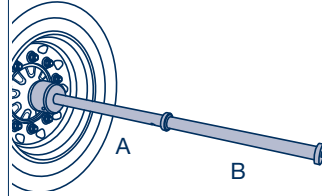
Number	Description	Illustration of tool	Tool in operation
5	<p>Measuring tube for aligning axles and suspension units</p> <p>BPW code number:  <b>15.001.01609</b>  <b>15.005.01609</b></p>		

### 3 Exploded view

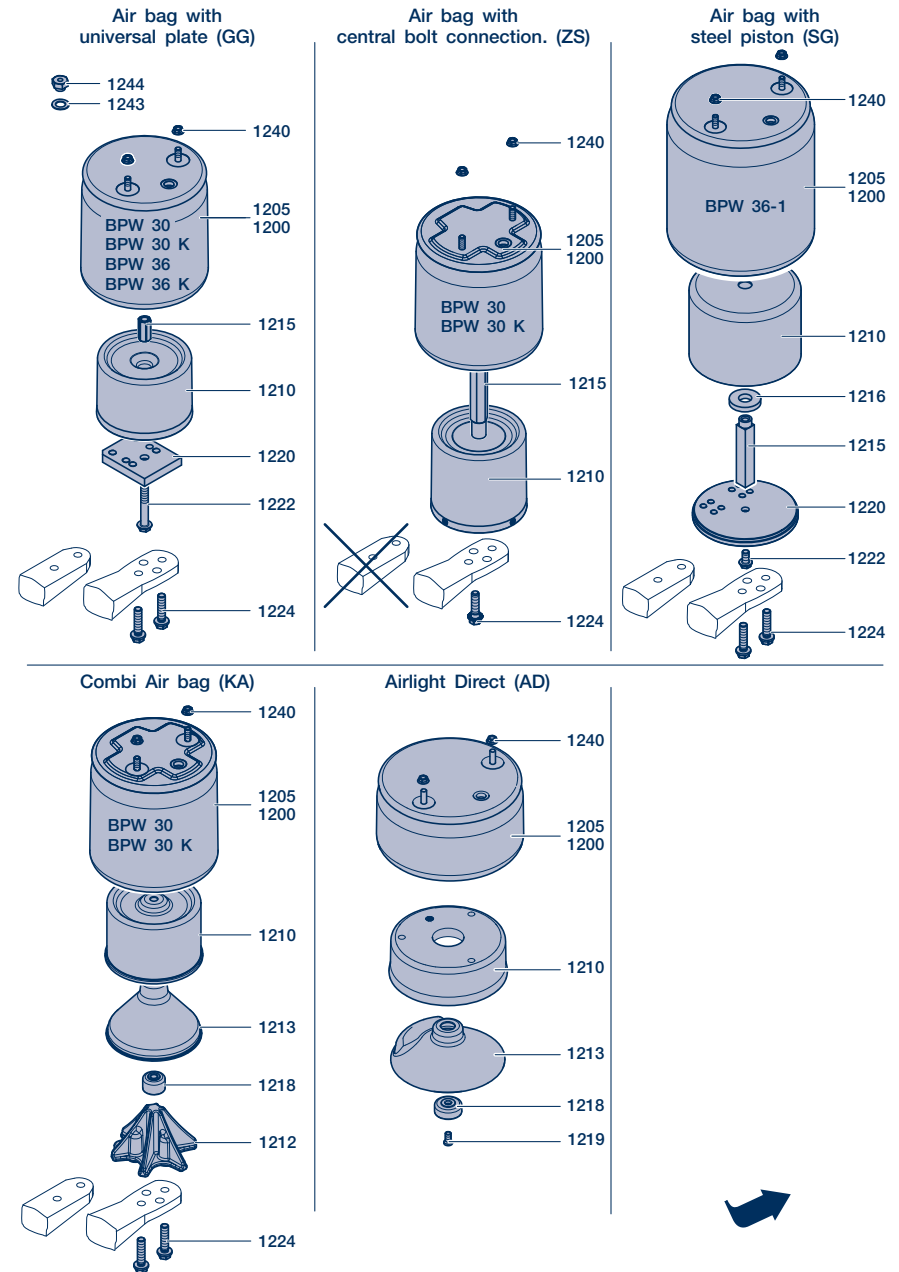

### 3 Exploded view

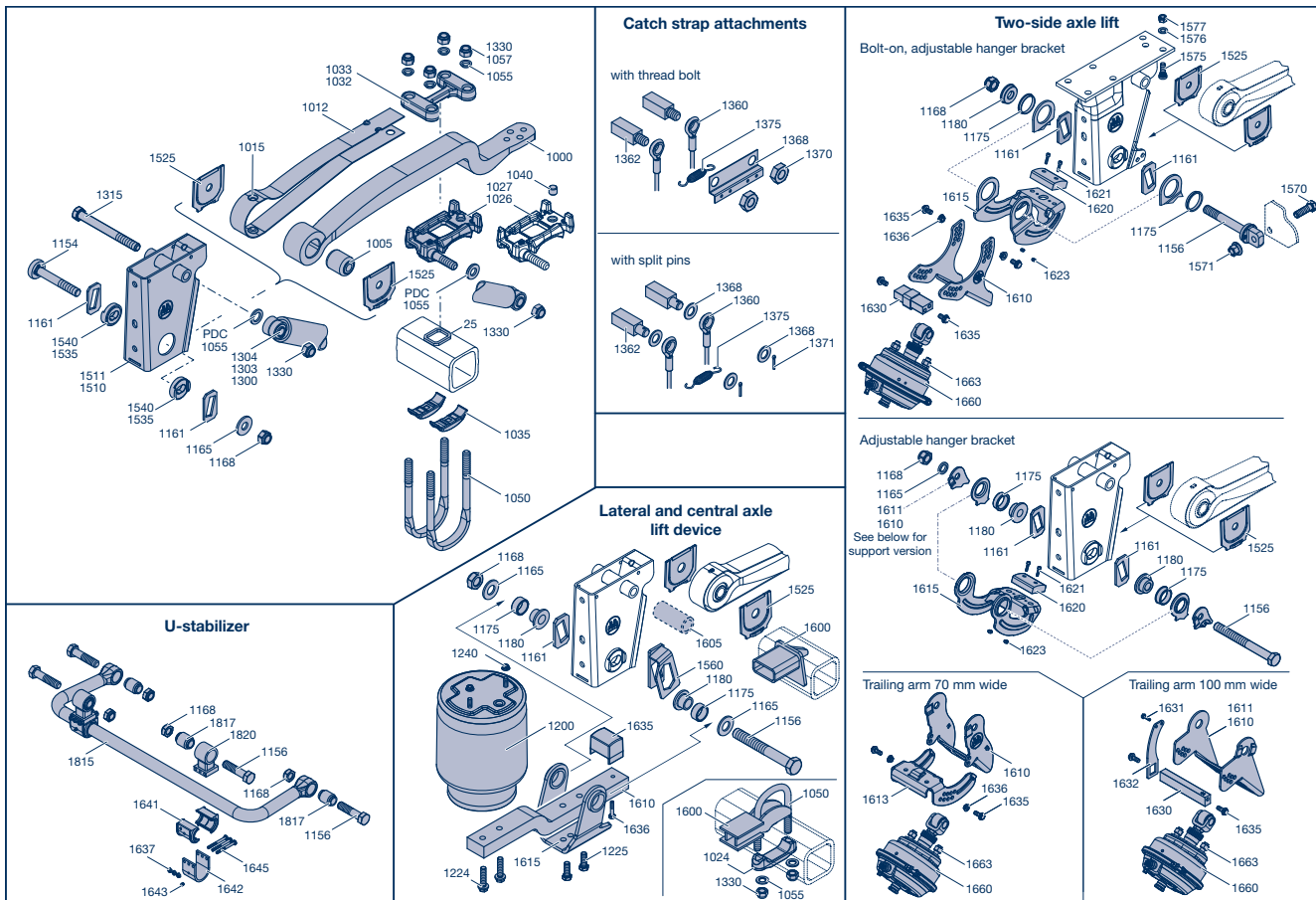

## Name

Item	Name	U-stabiliser	Lateral and central axle lift device
25	Centering frame	1156 Hexagon screw	1024 Spring pad
1000	Trailing arm	1168 Lock nut	1050 Spring U-bolt
1005	Bush	1637 Lock nut	1055 Washer
1012	Locking plate	1641 Bush with seals	1156 Hexagon screw (spring bolt)
1015	Plug	1642 Shaped plate	1161 Plate (adjusting plate)
1018	Spring screw	1643 Grease nipple	1165 Washer
	(2-leaf trailing arm)	1645 Hexagon screw	1168 Lock nut
1019	Hexagon nut	1815 U-Bolt	1175 Bush
	(2-leaf trailing arm)	1817 Bush	1180 Bush
1024	Spring pad, Double latch	1820 Support	1200 Air bag assembly
1026	Spring pad		1224 Locking screw
1027	Spring pad		1225 Hexagon screw
1032	Spring plate	<b>Air bag</b>	1240 Lock nut
1033	Spring plate	1200 Air bag assembly	1330 Lock nut M 24
1035	Segment	1205 Air bag	1525 Shaped plate
1035	Spring pad	1210 Piston	(wearing plate)
1040	Centering bolt	1210 Piston support	1560 Connecting link disc with
1041	Tracking plate	(version AD)	anti-rotation device
1042	Centering plate,	1212 Hanger bracket (version KA)	1600 Support
	Centering ring	1213 Piston	1605 Tube
1050	Spring U-bolt	1215 Threaded sleeve	1610 Lifting arm
1053	Hexagon screw	(version GG)	1615 Support
1055	Washer	1215 Bolt (version ZS, SG)	1635 Bump stop
1055	Ring	1216 Ring	1636 Hexagon screw
1057	Nut M 22	1218 Nut (version KA)	
1154	Spring bolt	1218 Shaped part (version AD)	<b>Two-side axle lift</b>
1160	Slider	1219 Screw	1156 Spring bolt
1161	Plate (adjusting plate)	1220 Plate (version GG)	1161 Plate (adjusting plate)
1165	Washer	1220 Washer (version SG)	1168 Lock nut
1168	Lock nut	1222 Locking screw	1175 Bush
1300	Shock absorber	1224 Locking screw	1180 Bush
1303	Bush	1240 Lock nut	1525 Shaped plate
1304	Rubber bump stop	1243 Spring washer	(wearing plate)
1310	Thread bolt	1244 Shaft nut	1570 Hexagon screw
1315	Hexagon screw		1571 Hexagon nut
1318	Ring	<b>Check strap attachments</b>	1610 Shaped plate
1324	Hexagon screw	with threaded bolt	1610 Support
1327	Spacer sleeves	1360 Catch strap	1611 Support
1330	Lock nut M 24	1362 Threaded bolt	1613 Shaped plate
		1368 Shaped plate	1615 Lever
1510	Hanger bracket, rigid	1370 Hexagon nut	1620 Bump stop
1511	Hanger bracket, adjustable	1375 Return spring	1621 Cylinder head screw
1525	Shaped plate		1623 Lock nut
	(wearing plate)	with split pins	1630 Square bar
1530	Disc (aluminium hanger	1360 Catch strap	1631 Locking screw
	bracket)	1362 Bolt	1632 Plate
1531	Disc (aluminium hanger	1368 Washer	1635 Locking screw
	bracket)	1371 Split pin	1636 Lock nut
1535	Bush	1375 Return spring	1660 Diaphragm cylinder for axle
1540	Bush		lift
1570	Hexagon screw		1663 Hexagon nut
1571	Hexagon nut		
1575	Knurled screw		
1576	Washer		
1577	Lock nut		

## Tightening torque 4

Item	Description	Thread / Spanner size	Tightening torque
1057	Locking nut of Ubolts	M 22 / SW 32	M = 550 Nm (510 - 605 Nm)
1330		M 24 / SW 36	M = 650 Nm (605 - 715 Nm)
1168	Locking nut of spring pivot bolt or hexagon bolt on axle lift device	M 24 / SW 36	M = 650 Nm (605 - 715 Nm)
	Airlight II from 08/2001 up to 07/2001 channel crossmember	M 30 / SW 46	M = 900 Nm (840 - 990 Nm)
		M 30 / SW 46	M = 750 Nm (700 - 825 Nm)
		M 30 / SW 46	M = 900 Nm (840 - 990 Nm)
		M 30 / SW 46	M = 750 Nm (700 - 825 Nm)
1215	Screw connection threaded sleeve on air bag	M 16 / SW 24	M = 130 Nm
	Screw connection bolt on air bag	M 16 / SW 32	M = 130 Nm
1218	Lower central screw on the air bag piston	M 16 / SW 19	M = 130 Nm
1219	Locking screw on Airlight Direct air bag	M 12 / SW 8	M = 80 Nm
1222	Lower central screw on the air bag piston	M 16 / SW 22	M = 230 Nm
1224	Bottom securing bolt of air bags	M 16 / SW 22	M = 230 Nm - 300 Nm
	Central bolt		M = 300 Nm
1225	Mounting bracket screw, side and centre-mounted lift axle system	M 16 / SW 22	M = 230 Nm
1240	Top locking screws of air bags	M 12 / SW 17	M = 66 Nm
1324	Locking nut and hexagon screw for shock absorber	M 24 / SW 36	M = 420 Nm (390 - 460 Nm)
1330	Steel hanger bracket	M 24 / SW 36	M = 320 Nm (300 - 350 Nm)
	Aluminium hanger brackets	M 24 / SW 36	M = 320 Nm (300 - 350 Nm)
	Stainless steel hanger brackets		
1571	Bolted connection, gusset plate on spring bolts	M 18 x 1.5 / SW 27	M = 420 Nm (390 - 460 Nm)
1623	Bump stop fixing bolts, two-side axle lift	M 6 / SW 10	M = 8 Nm
1631	Locking screw of the side plate for two-side axle lift	M 8 / SW 13	M = 30 Nm
1635	Square bar fixing bolts for two-side axle lift	M 12 / SW 17	M = 130 Nm
1636	Bolted connection for shaped plate on two-side axle lift bracket	M 12 / SW 17	M = 75 Nm
	Bump stop fixing bolts for side and centre-mounted lift axle system	M 12 / SW 17	M = 66 Nm
		M 10 / SW 17	M = 25 Nm
1637	Fixing bolts of bracket for anti-roll bar (U-shape)	M 10 / SW 17	M = 53 Nm
1663	Securing nuts of diaphragm cylinder for axle lift	M 20 x 2.5 / SW 30	M = 350 - 380 Nm
		M 16 x 1.5 / SW 24	M = 180 - 210 Nm



## 5 Safety regulations, safety information

### 5.1 Safety regulations

- All work must be performed by trained mechanics at competent repair facilities or authorised specialist companies who have access to all relevant tools and have acquired the knowledge required for this work. Anyone who performs maintenance and repair work must be trained in automotive mechanics and already have experience in repairing trailers and semi-trailers. Anyone who performs brake work must be trained in brake systems.
- Comply with local safety regulations.
- The relevant operation and service regulations as well as safety regulations of the vehicle manufacturer and of the manufacturers of other vehicle parts must be adhered to.
- The vehicle must be prevented from moving during repair work. Please observe the relevant safety regulations for repair work on commercial vehicles, in particular the safety regulations for jacking up and securing the vehicle.
- For all welding operations, the hangers, U-bolts, air bags and plastic lines must be protected against flying sparks and weld spatter.
- The earth terminal should under no circumstances be attached to the trailing arm, U-bolt or wheel hub.
- Do not carry out any welding on the trailing arm.
- Do not machine the trailing arms with cutters or grinders. The spring seat guides should always be widened if replacement trailing arms do not fit exactly into the bed of the axle spring seats.
- It is not permitted for the hanger brackets to be heated for straightening work!
- During repair work, make sure that the brake is not operated inadvertently. The brake must be released.
- Do not perform repair work unless wearing protective clothing (gloves, safety boots, safety goggles, etc.) and using the recommended tools.
- Only use recommended tools.
- A second technician must provide assistance when carrying out work with heavy components (trailing arms, stabilisers, brake discs, brake drums or during brake back disassembly or assembly).
- All air lines and components must be depressurised before being removed.
- Following each repair, perform a function check or a test drive in order to make sure that the brakes and suspensions are functioning correctly. New brake linings only have maximum effect after a few braking actions. Avoid hard braking.
- All exchanged components must be reused or disposed in accordance with the applicable environmental regulations, laws and directives.
- The remaining thickness of the brake lining and the condition of the brake disc or brake drum must be visually inspected at regular intervals with respect to the way in which the vehicle is used (see BPW maintenance instructions).
- Tighten all fixings to the recommended tightening torque.

### 5.2 Safety regulations

This workshop manual contains different types of safety instructions, each of which is designated an icon and a key word. The key word describes the severity of the potential danger.



Warning!

Possible potential danger of serious or fatal injury (severe injury or death).

Caution!

Possible dangerous situation (slight injury or damage to property).



Repair Guide!

Risk of damage to property or consequential damage if this information is not observed.



Note!

Application hints and especially useful information.

It is essential that all maintenance work is carried out in accordance with the prescribed intervals in order to maintain the safe operation and roadworthiness of the trailer. The relevant operation and service regulations of the vehicle manufacturer and of the manufacturers of other vehicle parts must also be adhered to.

Rectification of any defects which are discovered or replacement of worn parts should be carried out by a BPW Service Centre or BPW Direct Service Partner unless the vehicle owner has the facilities, equipment and workshop manuals and possesses an official certificate to perform interim inspections or special brake inspections.

**When installing spare parts, it is strongly recommended that only original BPW components are used. Parts approved by BPW for trailer axles and suspensions regularly undergo special test procedures. BPW accepts product responsibility for them.**

**However, BPW cannot assess every single third-party product as to whether it can be used for BPW trailer axles and suspensions without any risk to safety. This applies even if such products have already been tested by an accredited test authority.**

**The warranty becomes null and void if spare parts other than original BPW parts are used.**

## 6 Care and Maintenance

Overview	Within 2 weeks of first journey under load, latest after 2000 km <sup>1)</sup>	Visual checks during the warranty period for chassis fitted with ECO Plus air suspension after 12, 36, 60 and 72 months	Annually <sup>2)</sup>
For detailed description, see pages 22 - 30			
① Grease U-stabiliser bearing bushes with BPW special longlife grease ECO-Li <sup>Plus</sup> and check for wear.	①		① <sup>3)</sup>
- Visual inspection, check all component parts and welding seams for damage and wear.		-	- <sup>3)</sup>
1 Check strap: Check condition and fastening.		1	1
2 Check air suspension levelling valve for condition, seal-tightness and general tightness.		2	2
3 Check condition of air bags.		3	3
4 Check shock absorber fastening for tightness. Tightening torque with a torque wrench: M 24 (SW 36) M = <b>420 Nm</b> (390 - 460 Nm) For aluminium and stainless steel hanger brackets: M 24 (SW 36) M = <b>320 Nm</b> (300 - 350 Nm)	4	4	4
5 Check spring pivot bolts for tightness. Tightening torque with a torque wrench: Hanger brackets and channel crossmember Airlight II from 09/2007: M 24 (SW 36) M = <b>650 Nm</b> (605 - 715 Nm) Hanger brackets from 8/2001: M 30 (SW 46) M = <b>900 Nm</b> (840 - 990 Nm) Hanger brackets up to 7/2001: M 30 (SW 46) M = <b>750 Nm</b> (700 - 825 Nm) Channel crossmember: M 30 (SW 46) M = <b>900 Nm</b> (840 - 990 Nm)	5	5	5
6 Check spring mounting kit for tightness. Tightening torque with a torque wrench: M 20 (SW 30) M = <b>340 Nm</b> (315 - 375 Nm) M 22 (SW 32) M = <b>550 Nm</b> (510 - 605 Nm) M 24 (SW 36) M = <b>650 Nm</b> (605 - 715 Nm) When mounting new spring mounting kits for Airlight II: M 22 (SW 32) M = 550 Nm + 90° angle tightening	6	6	6

<sup>1)</sup> ECO Plus Units with Airlight II and Airlight Direct air suspension are maintenance-free in On-Road applications and do not need to be retightened (see warranty documents ECO Plus.)

<sup>2)</sup> Under extreme conditions, with more frequency

<sup>3)</sup> Check twice annually.

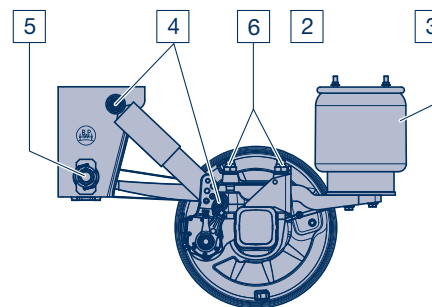

Series ALO/SLO

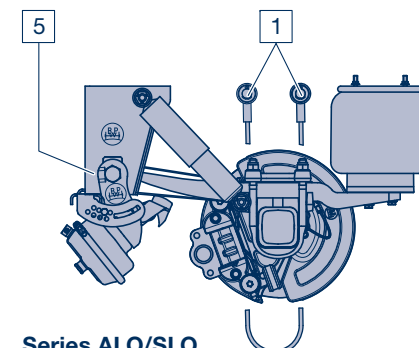

Series ALO/SLO  
with two-sided axle lift

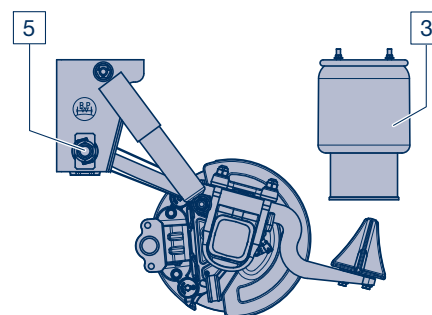

Series ALM/SLM with Combi Air bag II

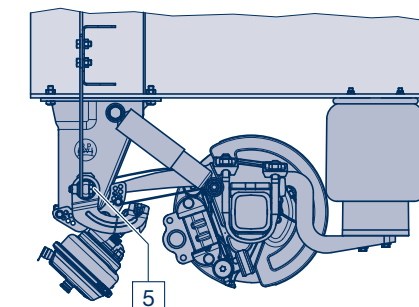

Series ALM/SLM with bolted-on  
air suspension hanger bracket

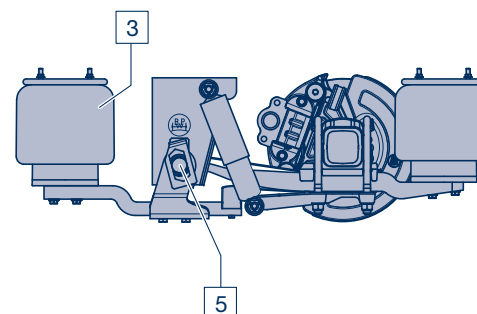

Series ALU/SLU with  
sidewise mounted axle lift

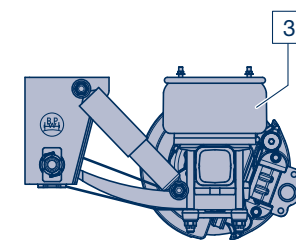

Series DLU - Airlight Direct

## 6 Care and Maintenance

Overview	Within 2 weeks of first journey under load, latest after 2000 km <sup>1)</sup>	Visual checks during the warranty period for chassis fitted with ECO Plus air suspension after 12, 36, 60 and 72 months.	Annually <sup>2)</sup>
For detailed description, see pages 22 - 30  <b>7</b> Check the bolt connection between the air suspension hanger bracket and the longitudinal member for tightness. Tightening torques with a torque wrench: M 16 M = <b>260 Nm</b> (240 - 285 Nm)	7	7	7
<b>8</b> Tighten the spring bolt to gusset plate connecting bolt. Tightening torques with a torque wrench: M 18 x 1.5 (SW 27) M = <b>420 Nm</b> (390 - 460 Nm)	8	8	8
<b>9</b> Check axle lift for tightness. Tightening torques with a torque wrench: Cylinder M 20 (SW 30) M = 350 - 380 Nm M 16 (SW 24) M = 180 - 210 Nm Supporting arm M 16 (SW 22) M = 230 Nm Hexagon screw M 12 (SW 17) M = 75 Nm	9	9	9
<b>10</b> Check air bag fastening for tightness. Tightening torques with a torque wrench: M 12 (SW 17) M = 66 Nm M 16 (SW 22) M = 230 - 300 Nm  Lower attachment - centre screw M 16 (SW 22) M = 300 Nm	10	10	10
<b>11</b> Check U-stabiliser fastenings. Tightening torques with a torque wrench: M 10 (SW 17) M = 53 Nm M 30 (SW 46) M = <b>750 Nm</b> (700 - 825 Nm)	11	11	11

<sup>1)</sup> ECO Plus Units with Airlight II and Airlight Direct air suspension are maintenance-free in On-Road applications and do not need to be retightened (see warranty documents ECO Plus).

<sup>2)</sup> Under extreme conditions, with more frequency.

### Note:

Components that have damage due to improper mounting are to be exchanged after a review by a BPW Service Centre.

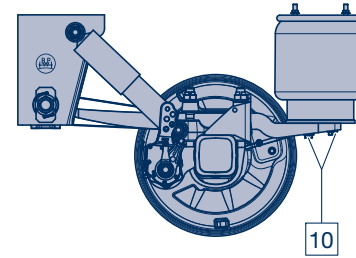

Series ALO/SLO

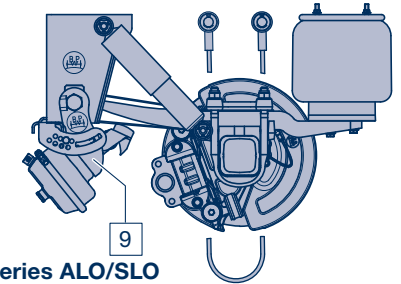

Series ALO/SLO  
with two-sided axle lift

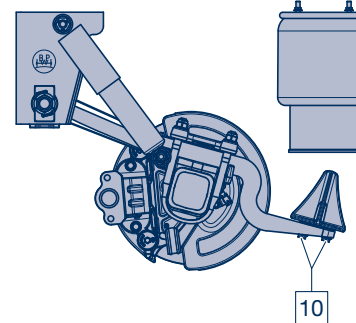

Series ALM/SLM with Combi Air bag II

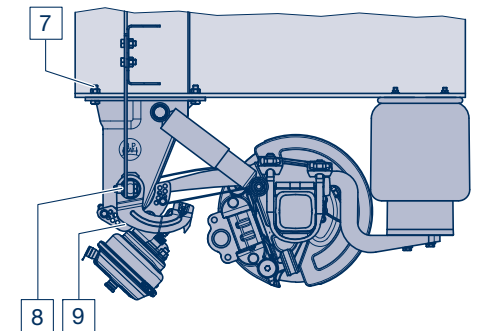

Series ALM/SLM with bolted-on air suspension hanger bracket and bolt-on double-sided lift

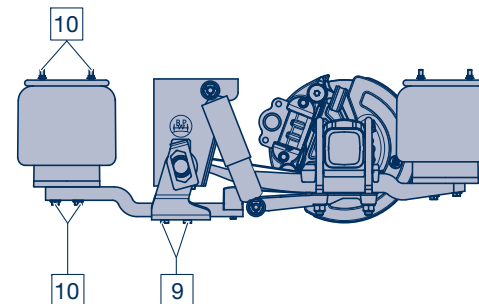

Series ALU/SLU  
with sidewise mounted axle lift

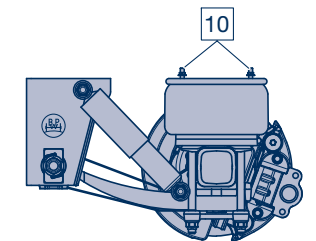

Series DLU - Airlight Direct

## 6 Care and Maintenance

### 1 U-stabiliser bearing bushes

– Service intervals as shown on page 18 –

Grease U-stabiliser bearing bushes with BPW special longlife grease ECO-Li<sup>Plus</sup> and check for wear.

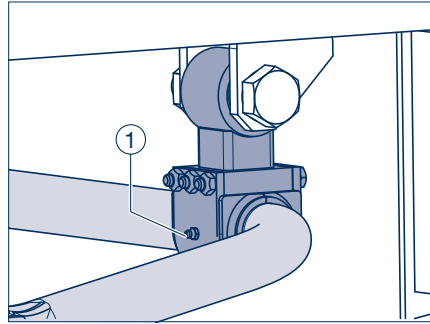

### - Visual inspection

– Service intervals as shown on page 18 –

Check all component parts and welding seams for wear and damage.

### 1 Check straps

– Service intervals as shown on page 18 –

Examine check straps and attachment. Replace if necessary. Check axle beam for wear.

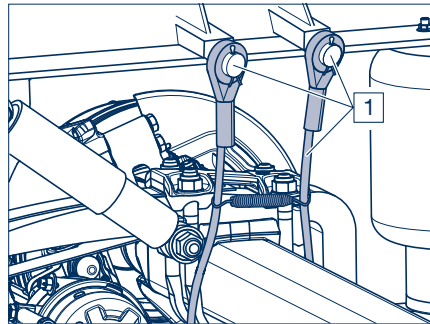

### 2 Air installation circuit

– Service intervals as shown on page 18 –

Check air installation valves and line connections for firm seating, damage and seal tightness. Check valve linkage and fastenings (arrows) for damage and tightness.

The length of the valve lever and permissible angular positions for the valve linkage are shown in the illustration below.

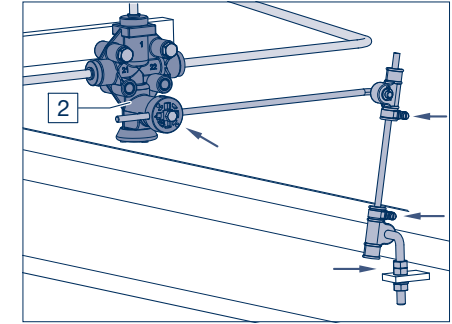

### Air suspension valve

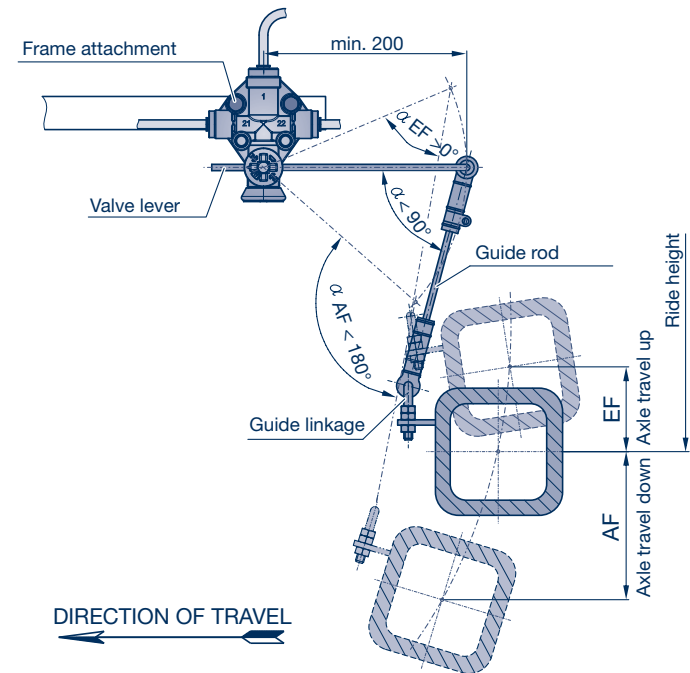

## 6 Care and Maintenance

### 3 Air bags

– Service intervals as shown on page 18 –

Check air bags for external damage (surface cracking, abrasion, crease formation, trapped foreign bodies etc.). Replace air bags in the event of damage.



#### **Danger! RISK OF INJURY!**

No welding should be carried out on steel parts of air bags and pressure vessel!

The air suspension should only be filled with compressed air when mounted.

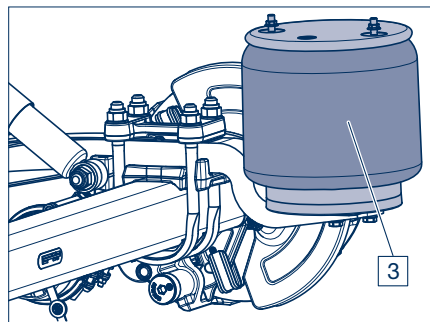

### 4 Shock absorber fastening

– Service intervals as shown on page 18 –

Check lower and upper shock absorber fastening for tightness. Tightening torques with a torque wrench.

Check condition and wear of the rubber bushing and replace where appropriate.

Check shock absorbers for oil leakage. In cases of distinct traces of oil, the shock absorber must be replaced. A light mist of oil is acceptable!

Tightening torque:

M 24 (SW 36) M = **420 Nm** (390 - 460 Nm)

In the case of aluminium and stainless steel hanger brackets:

M 24 (SW 36) M = **320 Nm** (300 - 350 Nm)

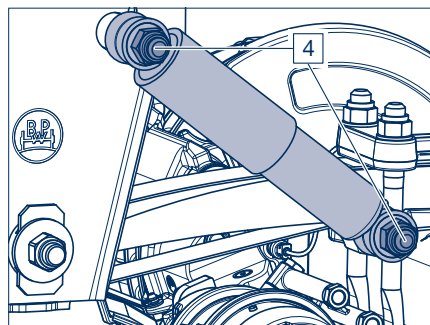

### 5 Spring pivot bolts

– Service intervals as shown on page 18 –

Check bushes, move vehicle back and forth slightly with the brake applied, or move rolled spring ends with the aid of a lever. No play should be present in the rolled spring end when doing so. If the fastening is loose the spring pivot bolt may be damaged.

- Check the lateral wear washers in the hanger bracket.
- Check the M 24 or M 30 lock nut on the spring pivot bolt for tightness.

Tightening torque with a torque wrench:

Air suspension hanger brackets and channel crossmember from 09/2007:  
M 24 (SW 36) M = **650 Nm** (605 - 715 Nm)

Hanger brackets from 08/2001:  
M 30 (SW 46) M = **900 Nm** (840 - 990 Nm)

Hanger brackets up to 07/2001:  
M 30 (SW 46) M = **750 Nm** (700 - 825 Nm)

Channel crossmember:  
M 30 (SW 46) M = **900 Nm** (840 - 990 Nm)

The serviceable life of the rubber / steel bush is dependent on the tightness of the inner steel bushing.

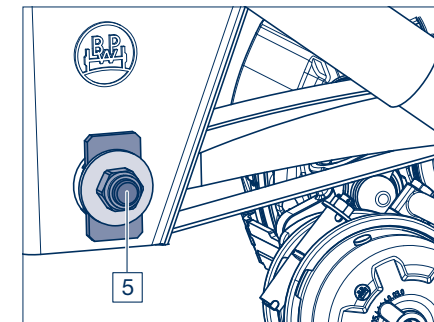

#### **Non-adjustable hanger bracket**

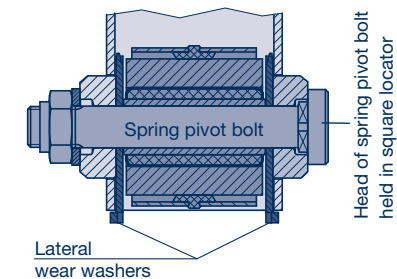

#### **Adjustable hanger bracket**

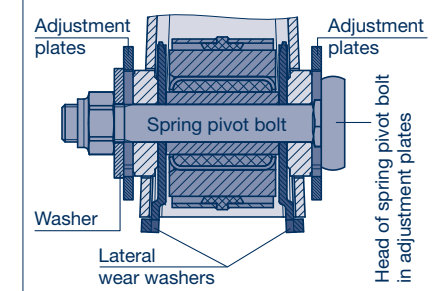

## 6 Care and Maintenance

### 6 Spring mounting kit

– Service intervals as shown on page 18 –

Check lock nuts of spring U-bolts for tightness. If loose, tighten nuts alternately a little at a time.

Tightening torques with a torque wrench:

M 20 (SW 30) M = **340 Nm** (315 - 375 Nm)

M 22 (SW 32) M = **550 Nm** (510 - 605 Nm)

M 24 (SW 36) M = **650 Nm** (605 - 715 Nm)

When mounting new spring mounting kit components for Airlight II, tighten the M 22 locknuts to a tightening torque of:

M = 550 Nm + 90° angle tightening.



#### Repair guide!

No welding should be performed on the trailing arm spring!

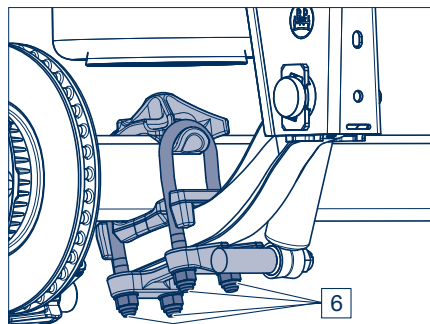
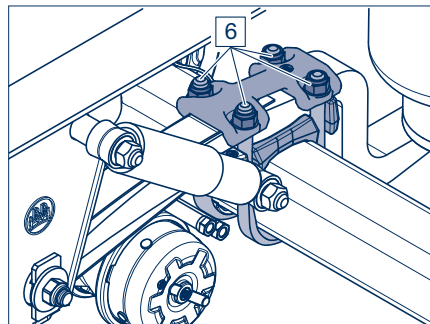

### 7 Bolted connection, air suspension hanger bracket to longitudinal chassis beam

– Service intervals as shown on page 20 –

Check that the mounting bolts of the air suspension hanger bracket on the longitudinal member are firmly tightened.

Tighten with a torque wrench if necessary.

Tightening torque:

M 16 M = **260 Nm** (240 - 285 Nm)

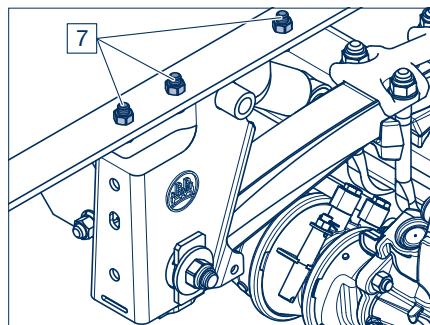

### 8 Bolted connection, gusset plate spring bolts

– Service intervals as shown on page 20 –

Check the mounting bolts of the gusset plates on the spring bolts are firmly tightened, and retighten with a torque wrench if necessary.

Tightening torque:

M 18 x 1.5 (SW 27) M = **420 Nm** (390 - 460 Nm)

Installing or renewing the spring bolt:

1. Unscrew or install the spring bolt.
2. Loosely pre-mount the gusset plate with at least three M 16 bolts at the top on the crossmember and one M 18 bolt at the bottom on the spring bolt and tighten further until contact is made.
3. Set the track.
4. Tighten the spring bolt to the prescribed tightening torque.
5. Tighten the connecting bolt on the gusset plates spring bolt and then tighten the upper connecting bolt to the prescribed tightening torques.

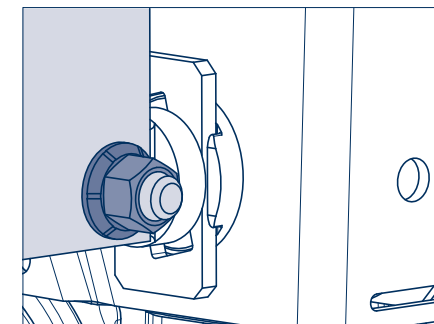
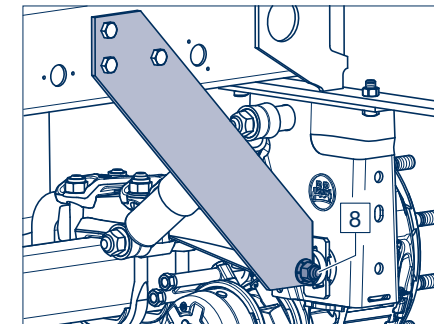

## 6 Care and Maintenance

### 9 Axle lift

– Service intervals as shown on page 20 –

#### Single-sided lift

Check the M 16 lock nuts on the lever arm fixing to make sure they are tight. Tighten with a torque wrench if necessary.

Tightening torque:

M 16 (SW 22)                      M = 230 Nm

Check for wear on the bump stop on the lever arm. Make sure it is secure.

Tightening torque:

M 10 (SW 17)                      M = 25 Nm

M 12 (SW 17)                      M = 66 Nm

#### Two-sided lift:

a) Check the M 16 lock nuts on the diaphragm cylinder to make sure they are tight. Tighten with a torque wrench if necessary.

Tightening torque:

M 20 (SW 30)                      M = 350 - 380 Nm

M 16 (SW 24)                      M = 180 - 210 Nm

b) Check the bump stop on the lever arm for wear, and that the M 6 attachment bolts are firmly tightened.

c) Check that the attachment bolts of the front bracing strut of the mount on the air suspension hanger bracket are tight, and in the case of the bolt-on two-sided lift, the bolted connection on the air suspension hanger bracket.

Tightening torque:

M 12 (SW 17)                      M = 75 Nm

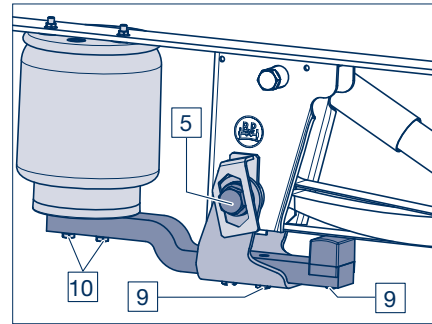

Single-sided lift

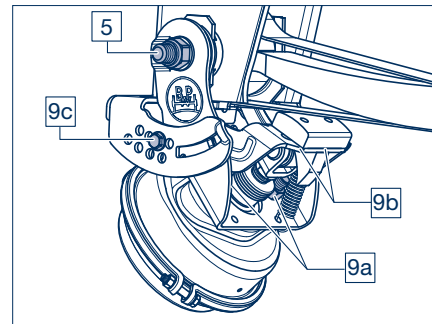

Two-sided lift

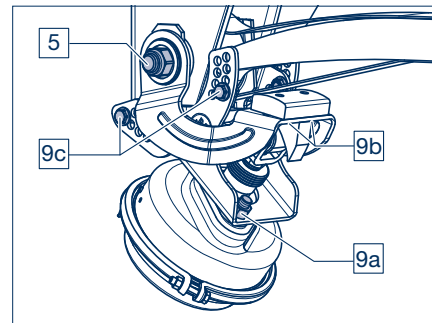

Bolt-on double-sided lift

### Spring pivot bolt bearing with axle lift

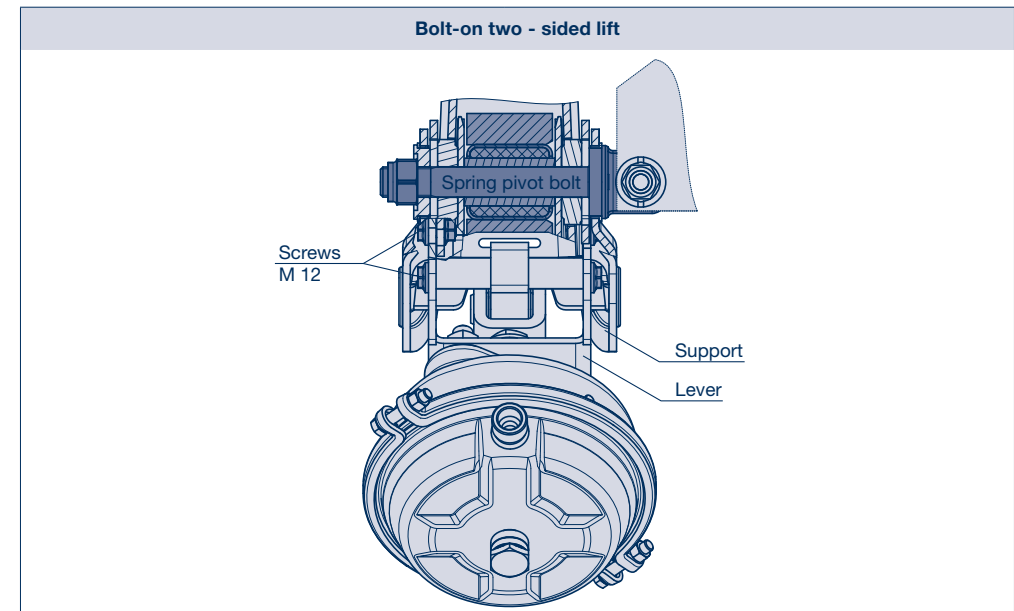
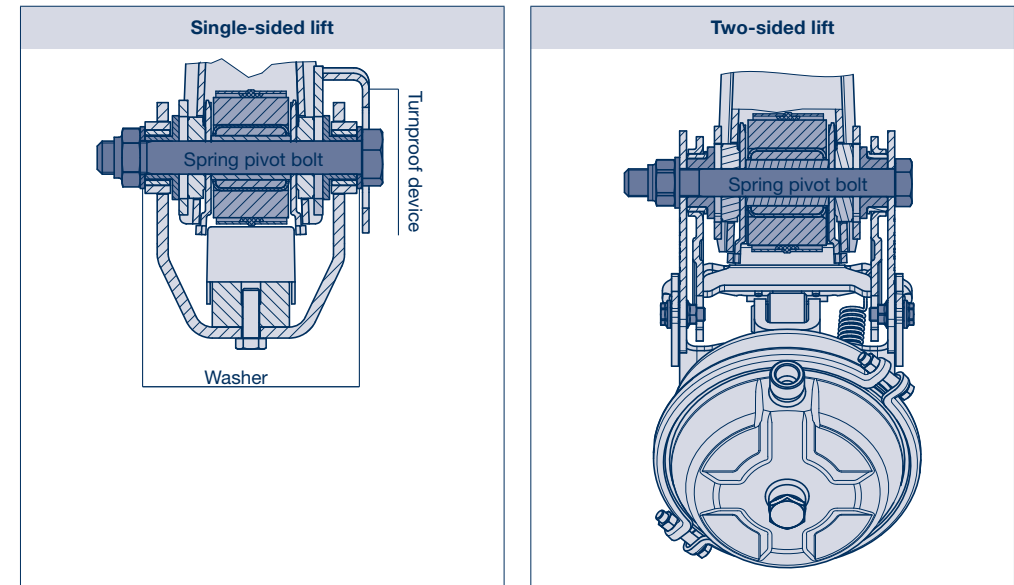

## 6 Care and Maintenance

### 10 Air bag fastenings

– Service intervals as shown on page 20 –

Check air bag fixing bolts or nuts for tightness.  
If necessary retighten using torque wrench.

Tightening torques:

M 12 (SW 17)	M = 66 Nm
M 16 (SW 22)	M = 230 - 300 Nm

Lower attachment - centre screw:

M 16 (SW 22)	M = 300 Nm
--------------	------------

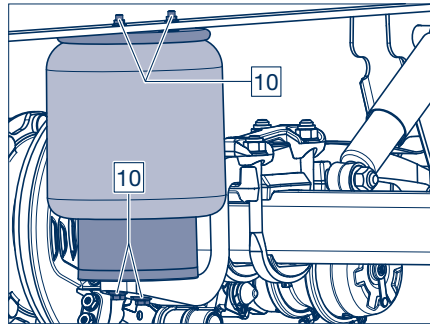

### 11 U-stabiliser

– Service intervals as shown on page 20 –

Check U-stabiliser bearings for wear and tightness.

Tightening torques with a torque wrench:

M 10 (SW 17)	M = 53 Nm
M 30 (SW 46)	M = <b>750 Nm</b> (700 - 825 Nm)

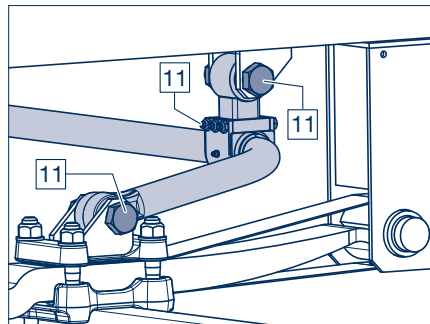



## 7 Dismantling and assembly of axle and trailing arms

### Dismantling

Note the ride height (FH) of the air suspension at its normal setting. To do this, measure the distance from the axle to the lower edge of the frame and record it.

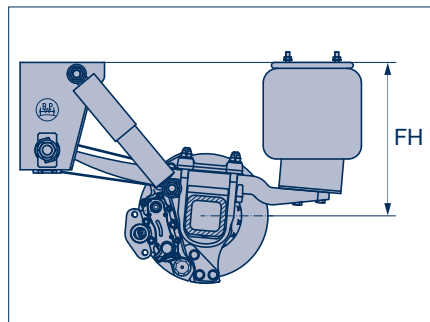

Picture 1

- [1] Secure vehicle to prevent rolling away.
- [2] Raise vehicle, inflate air bags to maximum height by setting lever for rotary disc valve / change-over valve on air suspension to „Lift” and then to „Stop”.

On air suspension systems without rotary disc valve / change-over valve, unscrew nut (picture 3/2) on linkage (picture 3/1) for air spring valve on axle and actuate the lever on the air suspension levelling valve until air bags have reached maximum height.

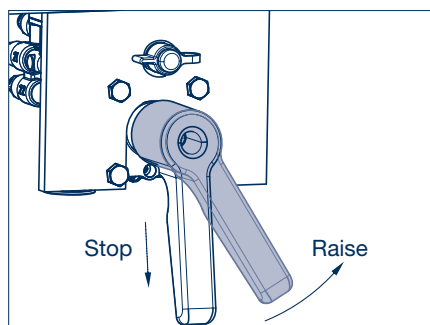

Picture 2

- [3] Support frame in this position to prevent accidents.
- [4] Release air from air bags by setting rotary disc valve / change-over valve on air suspension to „Lower”.

On air suspension systems without rotary disc valve / change-over valve, actuate valve lever on air suspension levelling valve until air has escaped from air bags.



**Warning!**  
**RISK OF INJURY** when working on air bags under pressure!

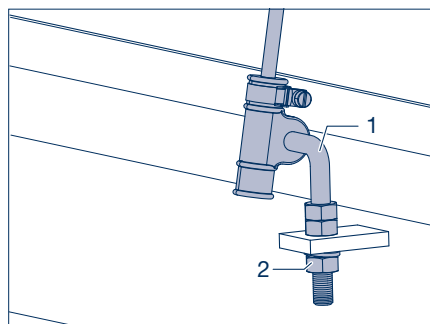

Picture 3

- [5] Lift axle slightly with vehicle jack and remove wheel, if required.

- [6] Vent the brake system. If spring-type brake actuator fitted, eliminate preload.
- [7] Remove the parking brake cables, if necessary.
- [8] Disconnect the compressed air hoses from the brake cylinders.
- [9] Detach tension spring at the shut-off valve, if necessary.
- [10] Undo all cable connections to the axle (Brake Monitor, ABS sensor cable, etc.).

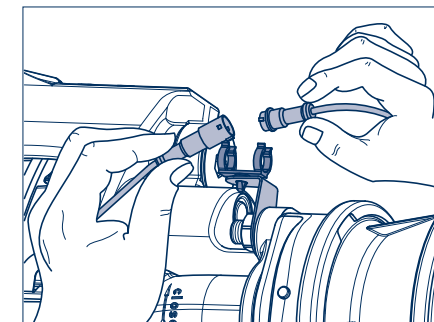

Picture 4

- [11] Remove the catch straps (1360), if necessary, see chapter 12.



**Repair guide!**  
If check strap attached with split pin bolt, the check strap only needs to be taken off at one side.

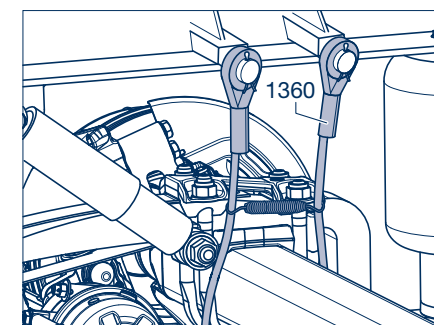

Picture 5

- [12] If the shock absorbers mountings have threaded pins, the shock absorbers (1300) must be removed by unscrewing the upper and lower lock nuts (1330, SW 36).

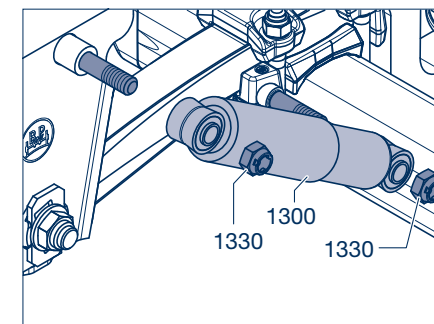

Picture 6

## 7 Dismantling and assembly of axle and trailing arms

-  If shock absorber attached between plates, remove bottom nut (1330) of the securing bolt (1324). Remove the bolt and spacer sleeves or washers (1318), if present.

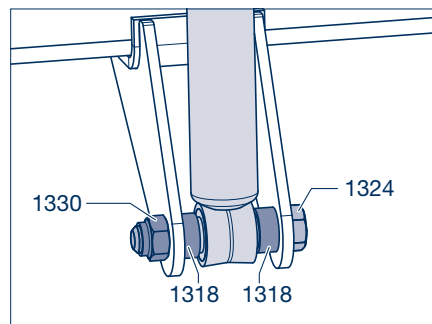

Picture 7

- [13] Support axle with movable vehicle lifter (low-lift platform truck) to prevent accidents.
- [14] Remove bottom locking bolt(s) (1224, SW 22), depending on design of air bag (1200).



**Repair guide!**  
Not required for Airlight Direct air suspension or combination air bag.

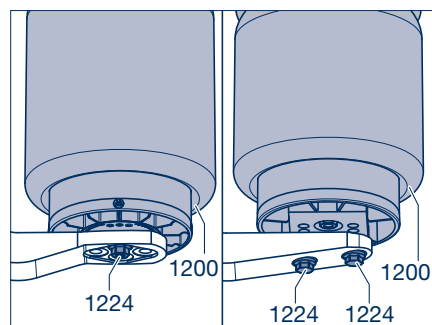

Picture 8

- [15] For air suspension with anti-roll bar (U-shape) (1815), remove the lock nuts (1168) from the mounting screws (1156) to the spring plates (1032, 1033) and pull out the mounting screws.

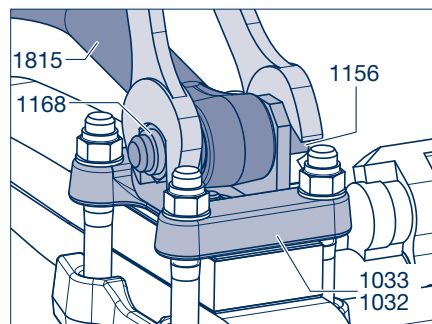

Picture 9

- [16] Unscrew locking nuts (1168, SW 36 / SW 46) of the spring pivot bolts (1154).
- [17] Remove the washers (1165) from adjustable air spring bracket with adjusting plate (1161).

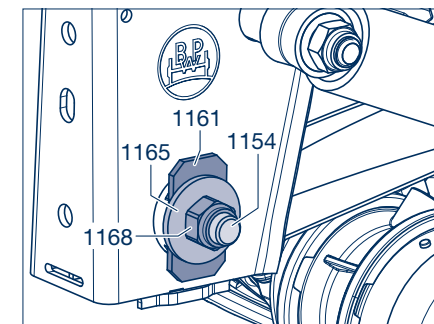

Picture 10

- [18] Drive spring pivot bolts (1154) out of the hanger brackets and of the trailing arm bushes (1000). In the case of the version with an adjustable hanger bracket take off the connecting link discs (1161).
- [19] Carefully let down and pull out the axle.

-  For axle lift device, see chapter 13.

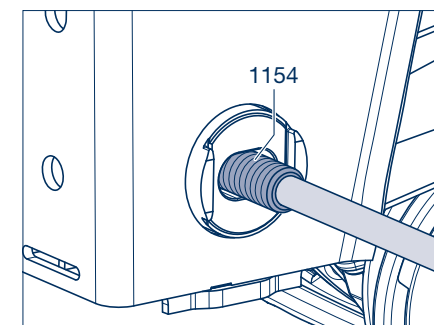

Picture 11

- [20] Examine wear plates (1525) in the steel hanger bracket (1510) for wear, and remove, if necessary. If wear plates are tack-welded, separate the components and tack-weld new ones. In case of loose mounted wearing plates, e.g. Airlight II, mount new tracking plates (1525).



**Repair guide!**  
Heating up of the hanger brackets for alignment work is not allowed.

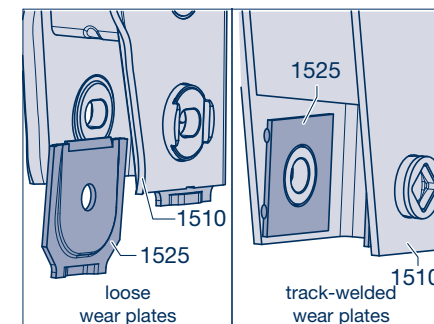

Picture 12

## 7 Dismantling and assembly of axle and trailing arms

### Replacement of worn weld-in bushes

- [21] Separate the worn bushes (1535, 1540) from the side plates of the support (1510, 1511).
- [22] Insert new bushes and harness with a distance sleeve or trailing arm bush (1005) and wear plates (1525) Align and tack weld centrally as well as horizontally. For adjustable supports; see Picture 13 (TA=trailing arm).
- [23] Disassemble bolting and fully weld the bushes. Seam thickness a 4  $\nabla$  to a 5  $\nabla$  (DIN EN ISO 25817)  
Welding technique:  
Gas-shielded welding, weld quality G 4 Si 1 (DIN EN 440) or E 46 2 (DIN EN 499) for arc welding rod electrodes.

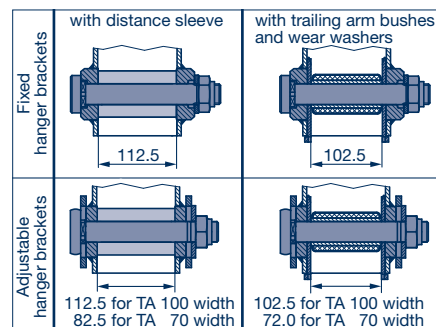

Picture 13

- [24] If alloy hanger brackets fitted, examine inner plates (1530) and outer plates (1531), drive out, if necessary and press in new plates.

 For the fitting and demounting of trailing arm springs, see chapter 8.

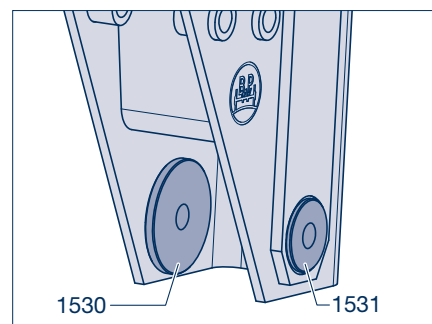

Picture 14

### Assembly

#### Version A: rigid hanger bracket

- [25] Place axle on movable vehicle lifter (low-lift platform truck) to prevent accidents, push below the frame and raise far enough until the holes of the trailing arm and hanger bracket are aligned.
- [26] Smear spring pivot bolt (1154) with grease and insert into the holes from the outside.



#### Repair guide!

We recommend mounting the spring bolt from the outside to the inside in order to make it easier to tighten the lock nuts over an inspection pit.

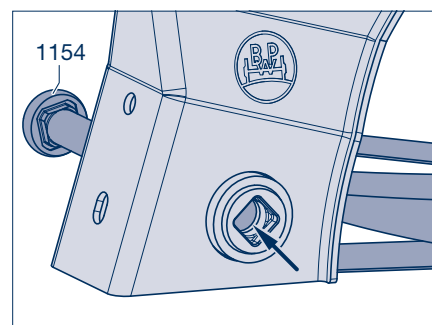

Picture 15

- [27] For loose wearing plates (1525), mount these from underneath between trailing arm (1000) and air spring bracket (1510, 1511).
- [28] Fully insert spring bolt (1154) until the square profile under the head of the spring bolt engages in the torsion protection (arrow) recess of the weld in bushes.

 See chapter 13 for the version with axle lift.

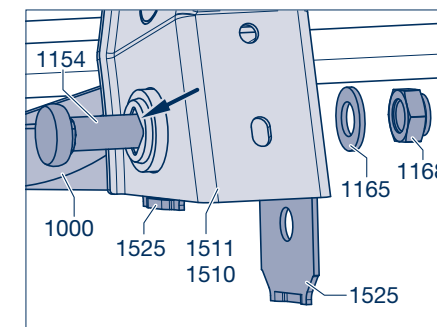

Picture 16

- [29] Push the plate (1165) onto the spring pivot bolt (1154), screw on new locking nuts (1168, SW 46) and tighten to the specified torque of:

Hanger brackets from 08/2001:  
M 30 (SW 46) M = **900 Nm** (840 - 990 Nm)

Hanger brackets up to 07/2001:  
M 30 (SW 46) M = **750 Nm** (700 - 825 Nm)

Channel crossmember  
M 30 (SW 46) M = **900 Nm** (840 - 990 Nm)

 See page 39 for the further installation procedure, starting from step [31].

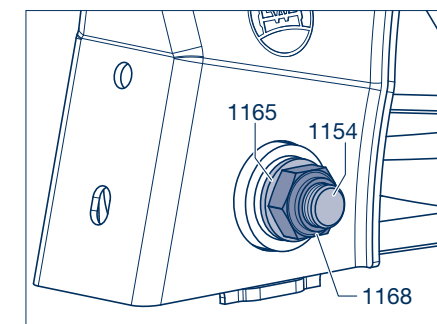

Picture 17

### Assembly

#### Version B: Adjustable hanger bracket

- [25] In the version up to 2001, apply grease to the sliding surfaces of the sliders (1160) and insert into the hanger bracket (1511) on the left and right until flush.
- [26] Place axle on movable vehicle lifter (low-lift platform truck) to prevent accidents, push below the frame and raise far enough until the holes of the trailing arm and hanger bracket are aligned. (The slide elements must remain in position.)

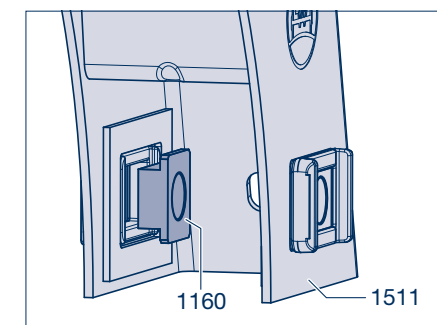

Picture 18

## 7 Dismantling and assembly of axle and trailing arms

- [27] In the version from 2001 onwards with loose shaped plates, e.g. Airlight II: mount the shaped plates (1525) from below between the hanger bracket (1511) and the trailing arm (1000) (make sure the holes in the trailing arm, hanger bracket and shaped plate line up).

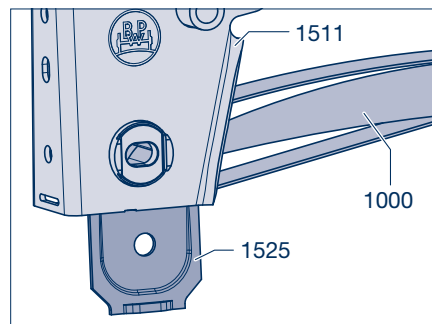

Picture 19

- [28] Push connecting link disc (1161) onto the square spring bolt, ensuring correct positioning of the connecting link disc.

- [29] Smear spring pivot bolt (1154) with grease and with the connecting link disc pushed on, fit into the spring eye from the outside. In doing so the connecting link disc must engage into the mouth of the hanger bracket.

See chapter 13 for the version with axle lift.

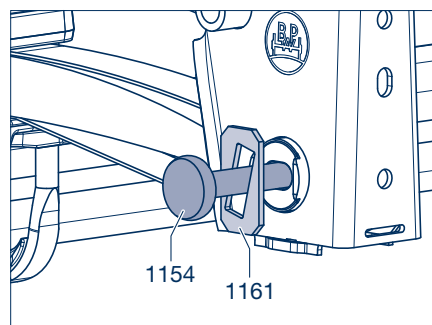

Picture 20

- [30] Fit connecting link disc (1161), washer (1165) and new lock nut (1168). The bevels of the connecting link discs must be flushed with one another and engaged in the mouth of the hanger bracket on both sides.



**Repair guide!**  
Do not tighten the lock nut!

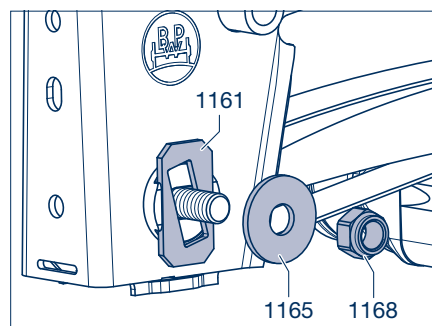

Picture 21

- [31] Lift the axle to the ride height as measured before step [1].

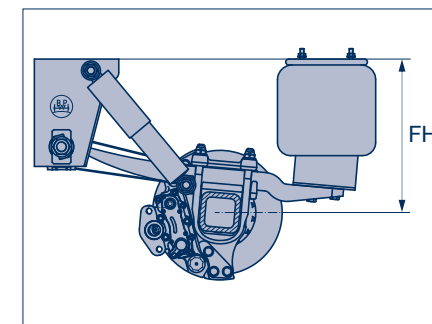

Picture 22

- [32] Align adjusting plates (1161) on both sides and centrally and evenly tighten lock nuts (1168, SW 36 / SW 46) – do not fully tighten until secure. (The spring bolt screw connection is tightened after the track of the axle has been adjusted.)

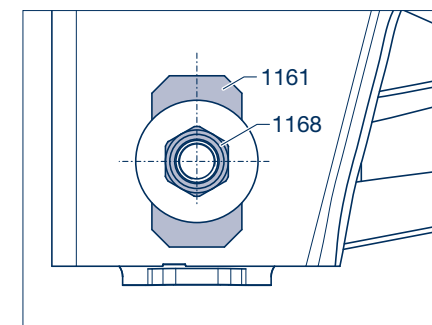

Picture 23

- [33] Clean the contact area of the air bag (1200) and the trailing arm (1000).

- [34] Position the air bag on the trailing arm.

Air bag with central bolt connection

- [35] Screw in locking screw M16 (1224, SW 22) and tighten to the specified torque of M = 300 Nm.

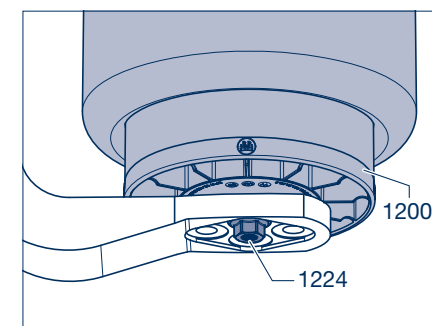

Picture 24

## 7 Dismantling and assembly of axle and trailing arms

### Air bag with universal and steel plate

- [35] Screw in locking screw M16 (1224, SW 22) and tighten to the specified torque of  $M = 230 - 300 \text{ Nm}$ .

-  If the hexagon screw (1222, SW 22) was loosened during disassembly, check the specified torque of  $M = 230 - 300 \text{ Nm}$ .

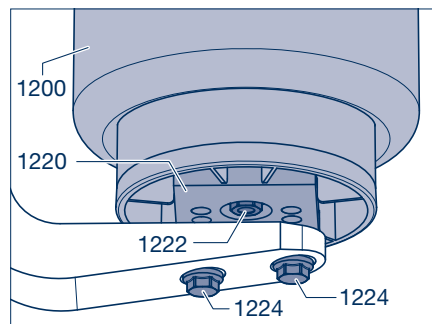

Picture 25



**Repair guide!**  
When using PDC shock absorbers, a distance washer (1055) as well as shorter lock nuts (1330) must be used in each case between support or spring pad and PDC.

- [36] If shock absorber (1300) attached to threaded bolt, mount the shock absorber with the protective sleeve facing up. Screw on new lock nuts (1330, SW 36) and tighten to the prescribed torque.

Tightening torque:

M 24                       $M = 420 \text{ Nm}$  (390 - 460 Nm)  
In the case of aluminium and stainless steel hanger brackets:  $M = 320 \text{ Nm}$  (300 - 350 Nm)

-  In the case of a shock absorber fastening between plates, depending on the version, insert washers or spacer sleeves (1318) between shock absorber eye and plate. Push in the fastening screw (1324), screw on the new lock nuts (1330, SW 36) and tighten to the prescribed torque, see step [36].

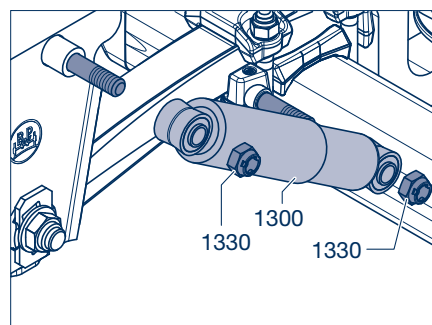

Picture 26

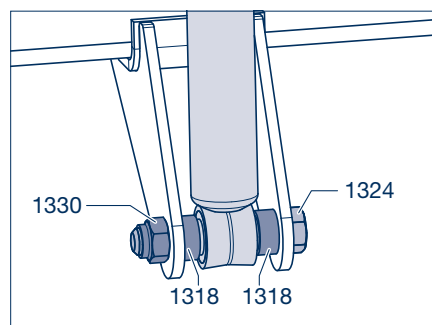

Picture 27

- [37] Install check straps (1360), see chapter 12.

- [38] If present, insert the extension spring of the shut-off valve into the bracket on the axle beam and attach to the shut-off valve.

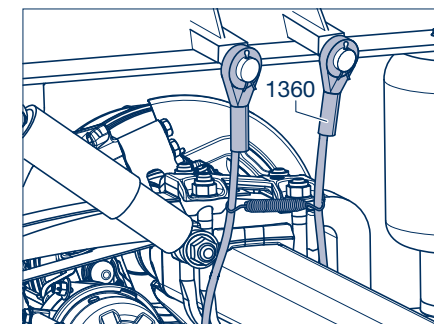

Picture 28

- [39] Re-connect the compressed air hose onto the brake cylinder.

- [40] Re-attach all cable connections to the axle (Brake Monitor, ABS sensor cable, etc.).

- [41] Fit the parking brake cables, if present.

- [42] Place the suspension linkage (Picture 30/1) of the air suspension valve in the bracket on the axle beam and secure with nut (Picture 30/2) and spring washer.

- [43] Replace wheels.

- [44] Inflate air bags and remove supports.

-  Check the air suspension valve setting, correct it to the originally measured ride height, if necessary, see chapter 14.

-  Perform axle alignment check, see chapter 16.

- [45] After adjusting the axle track, tighten the spring bolt nut (1168, SW 36 / SW 46) to the prescribed tightening torque.

Air suspension hanger brackets and channel crossmember Airlight II from 09/2007:  
M 24 (SW 36)     $M = 650 \text{ Nm}$  (605 - 715 Nm)

Hanger brackets from 08/2001:  
M 30 (SW 46)     $M = 900 \text{ Nm}$  (840 - 990 Nm)

Hanger brackets up to 07/2001:  
M 30 (SW 46)     $M = 750 \text{ Nm}$  (700 - 825 Nm)

Channel crossmember:  
M 30 (SW 46)     $M = 900 \text{ Nm}$  (840 - 990 Nm)

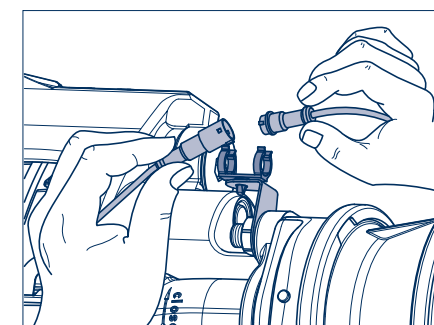

Picture 29

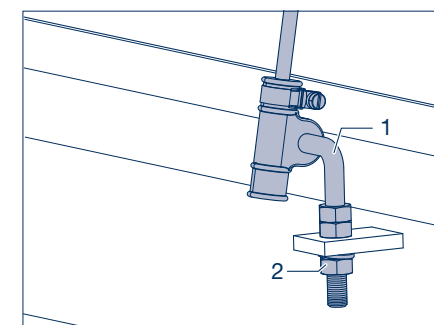

Picture 30

## 8 Dismantling and assembly of trailing arm

### 8.1 Dismantling

[1] Deflate air bags (1200), see page 32, steps [1] - [4].

[2] Support axle on the side on which the trailing arm is to be removed with movable vehicle lifter (low-lift platform truck) to prevent accidents.

[3] If air suspension system is fitted with a U-stabiliser, the securing bolts at the spring plates must be removed, see chapter 9, page 57.

[4] When the shock absorber is secured to the lower spring plate (1032, 1033) with a welded bolt, remove the mounting nut (1330) and shock absorber completely. In cases where the shock absorber is mounted to the upper spring plate, disconnect by removing the lower bolt and nut (1324, 1330).

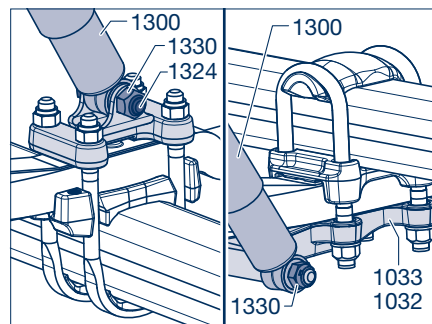

Picture 1

[5] Depending on the air bag version (1200), disassemble the lower locking screw(s) (1224, SW 22).

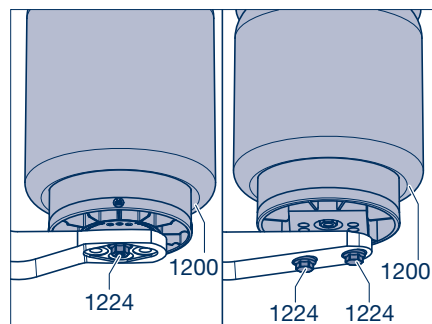

Picture 2

[6] Remove lock nut (1168, SW 36 / SW 46) from the spring bolt (1154).

[7] For air suspension with adjusting plate (1161), remove the nut (1168) and washers (1165).

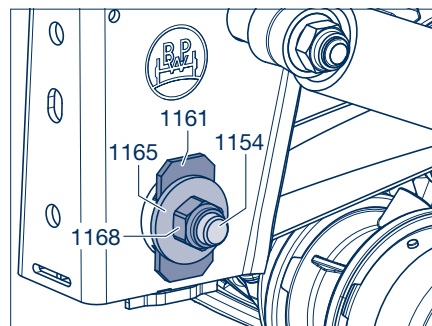

Picture 3

[8] Push out the spring bolt (1154) from the air suspension and the trailing arm (1000). For versions with an adjustable support, detach the adjusting plate (1161).

👉 If side axle lift device fitted, see chapter 13.

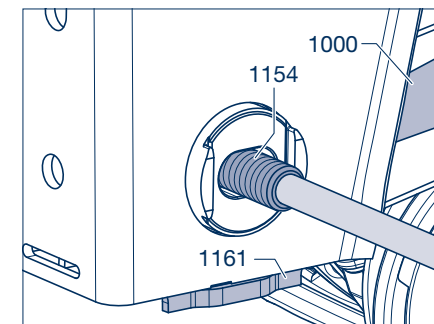

Picture 4



**Caution! RISK OF INJURY!**  
Secure the trailing arm against falling out. Use a hoist or ask a second person for assistance.



**Repair guide!**  
By loosening the U-bolts of the positive axle clamping, all components are slacked and can be easily detached and exchanged.

[9] Screw the lock nuts (1057, SW 32) (1330, SW 36) from the U-bolts (1050) and, if necessary, take off the washers (1055).

[10] Remove spring plate (1032, 1033), spring U-bolts and any segments (1035).

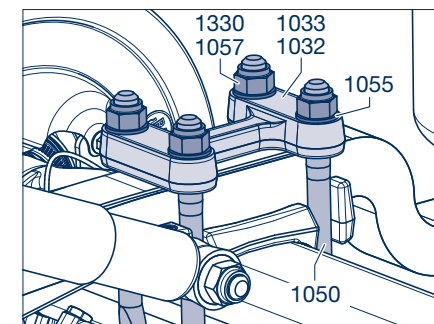

Picture 5

[11] For single-leaf springs with catch plate (1012), detach the trailing arm (1000) from the axle.

[12] In the case of axles with a positive axle clamping remove the centring bolt (1040) between trailing arm spring and catch plate hole, the tracking plate (1041, if present) and the spring seats (1026, 1027).

[13] Check steel/rubber/steel bush (1005) in the trailing arm spring for wear, replacing if necessary. See chapter 8.4.

[14] Check the centering frame (25) on the axle beam for wear and, if necessary, replace and re-weld.

[15] For axles with welded axle mounting, take out the tracking plate (1041), if present, from the axle spring seats. Any welded-on tracking plates must be ground off and welded back on again after a tracking check.

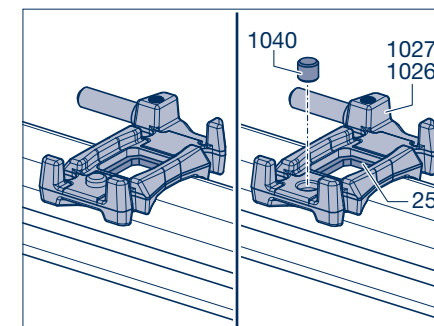

Picture 6

## 8 Dismantling and assembly of trailing arm

### 8.2 Assembly

- [16] Free the contact areas on the axle beam and axle mounting from dirt and welding spatter, and check condition.
- [17] For top-mounted air suspension, position the trailing arm (1000) on the axle beam or axle spring seats. For single-leaf springs, this should also include the catch plate (1012) and plug (1015).

For bottom-mounted air suspension, position the trailing arm (1000) under the axle beam. For single-leaf springs, this should also include the catch plate (1012) and plug (1015).



#### Repair guide!

For single-leaf spring, position the catch plate so that there is a clearance of 8 mm after installation (see detailed view, Picture 7).

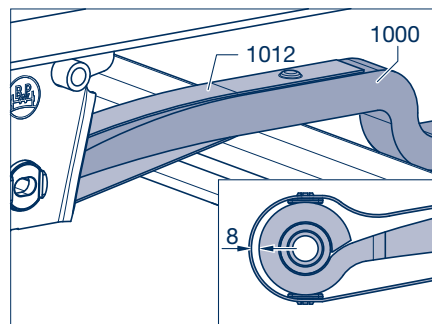

Picture 7

#### Non adjustable hanger bracket:

- [18a] Insert the trailing arm (1000) with the steel-rubber-steel bush in the support (1510) until the bore holes of the trailing arm and support are aligned.
- [19a] Smear spring pivot bolt (1154) with grease and insert into the hole from the outside.



#### Repair guide!

We recommend mounting the spring bolt from the outside to the inside in order to make it easier to tighten the lock nuts (1168) over the pit.

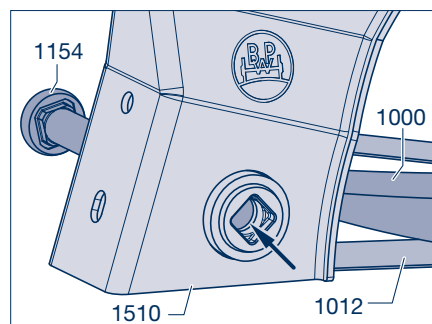

Picture 8

- [20a] For loose wearing plates (1525), mount these between trailing arm (1000) and air spring (1510).
- [21a] Fully insert spring bolt (1154) until the square of the spring bolt is in the torsion protection (arrow) of the weld-in bushes.

Go to Section 8.2.1 on page 46 for top-mounted air suspension or Section 8.2.2 on page 49 for bottom-mounted air suspension.

If side axle lift device fitted, see chapter 13.

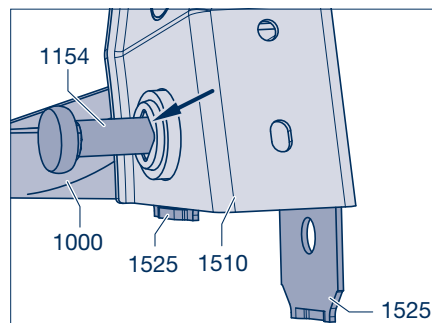

Picture 9

#### Adjustable support with sliders:

- [18b] For versions until 2001, grease the sliding surfaces of the sliders (1160) and place in the support (1511), aligning it to the right and left (1511).

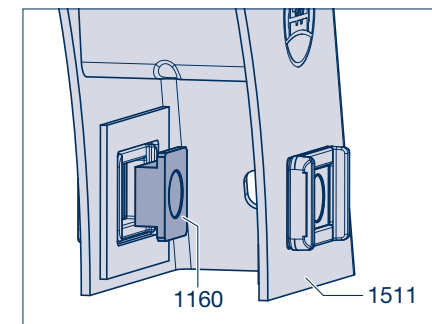

Picture 10

- [19b] Insert the trailing arm (1000) with the steel-rubber-steel bush between the slides (1160) in the support (1511) until the bore holes are aligned.

- [20b] Push connecting link disc (1161) onto the square spring pivot bolt.

- [21b] Smear spring pivot bolt (1154) with grease and insert into the hole from the outside.

Go to Section 8.2.1 on page 46 for top-mounted air suspension or Section 8.2.2 on page 49 for bottom-mounted air suspension.

If side axle lift device fitted, see chapter 13.

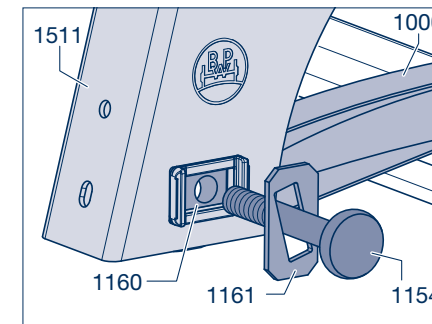

Picture 11

#### Adjustable support with round weld-in bushes:

- [18c] Insert the trailing arm (1000) with the steel-rubber-steel bush in the support (1511) until the bore holes of the trailing arm and support are aligned.

- [19c] Mount the wearing plates (1525) from below, between support (1511) and trailing arm (1000) (pay close attention to the alignment of the bore holes of trailing arm, support and shaped plate).

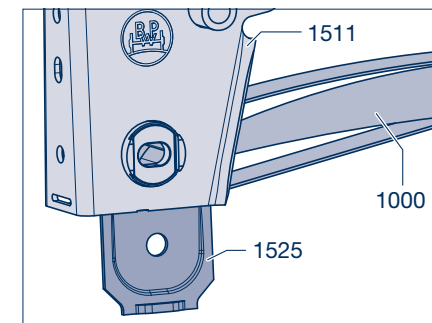

Picture 12

## 8 Dismantling and assembly of trailing arm

[20c] Slide the adjusting plate (1161) onto the square of the spring bolt. Pay close attention to correct positioning of the adjusting plate.

[21c] Grease the spring bolts (1154) and mount in the spring eye with a suspended adjusting plate from the outside. The adjusting plate should mesh with the support jaw.

 If side axle lift device fitted, see chapter 13.

 For versions with bottom-mounted trailing arm, continue in Section 8.2.2, page 49.

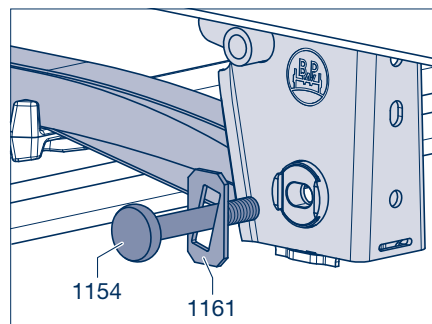

Picture 13

### 8.2.1 Top-mounted air suspension (trailing arm over the axle)

SLO/SLM - ALO/ALM

 To fit the spring mounting kit components, lift the trailing arm slightly.

[22] Align spring seats (1026, 1027) with the axle beam centring ring (25). (Not used in welded axle connections.)

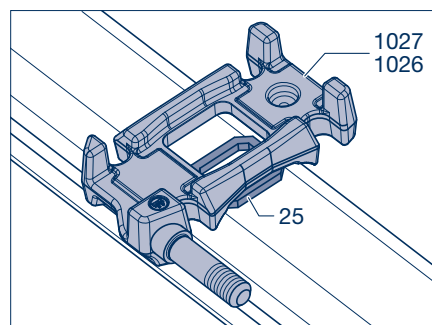

Picture 14

### Clamping of trailing arm without tracking plate (only with single-leaf spring for centering bolt)

[23] Place the centering bolt (1040) in the axle spring seats (1026, 1027) or the bore hole of the trailing arm (1000) / catch plate (1012).



**Note:**  
In newer versions, the centering bolt is already forged onto the axle spring seats.

 See page 48 for further installation with step [24].

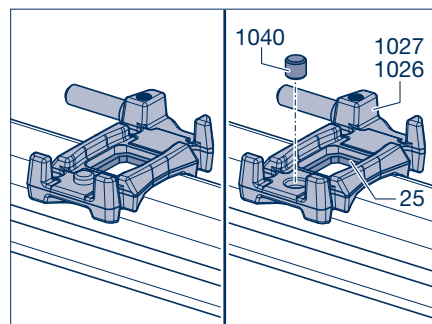

Picture 15

### Clamping of trailing arm with centering bolt on tracking plate

[23] Place the tracking plate with mounted centering bolt (1041) into the bore hole of the trailing arm (1000) / catch plate (1012) or into the axle spring seats (1026, 1027).

 See page 48 for further installation with step [24].

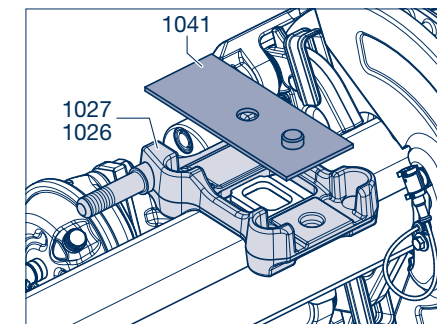

Picture 16

### Two-part trailing arm with spring screw

[23] Insert the tracking plate (1041) centred into the axle spring seats (1026, 1027) or attach it to the head of the centre bolt (1018) in the trailing arm (1000).

 See page 48 for further installation with step [24].

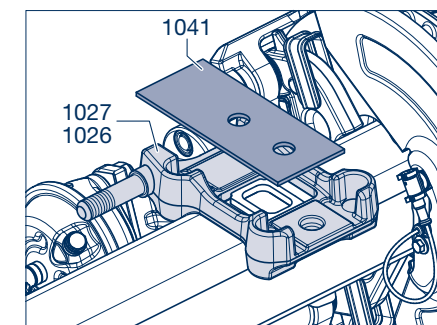

Picture 17

### Twin leaf trailing arm with centre bolt

#### Centering ring / centering plate for adjustable support

[23] Place the centering plate or centering ring (1042) in the axle spring seats (1026, 1027) on the welded-centring frame (25) on the axle body and centre the axle spring seats. The tracking plate (1041) is not needed.

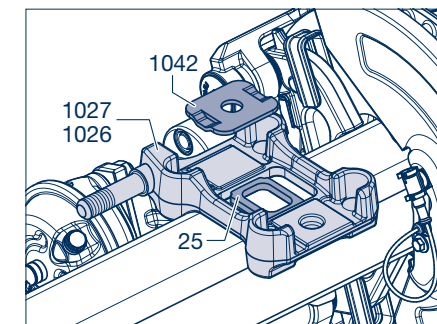

Picture 18



## 8 Dismantling and assembly of trailing arm

[24] Lay the trailing arm spring (1000) complete with centring bolt or tracking plate (1041) in the spring seat (1026, 1027).

[25] Fit new spring U-bolts and segments (1035).



### Repair guide!

For attachment of the trailing arm with hexagon screws (1053), these are mounted according to step [27].

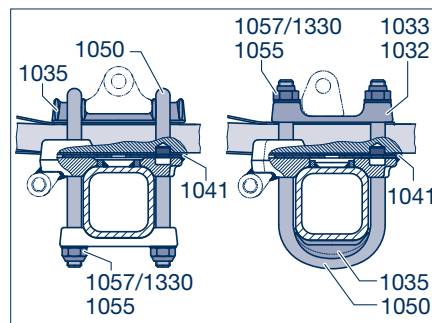

Picture 19

[26] Depending on the spring plate version (1032, 1033), mount the axle spring seats (1024) or double latch (1024) onto the U-bolt ends.

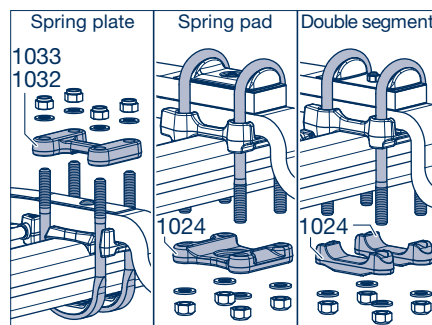

Picture 20

[27] Attach new discs (1055).

[28] Lightly grease the threads of the new U-bolts (1050) / hexagon screws (1053) and the nut contact area.

[29] Unscrew the new lock nuts (1057, SW 32) (1330, SW 36) by hand on the U-bolt / hexagon bolts.



### Repair guide!

A rounded washer must be fitted for spring plates with spherical countersink.

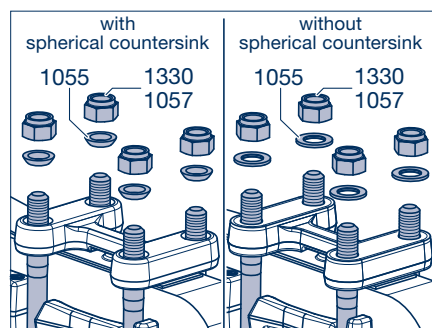

Picture 21

[30] Align the axle under the vehicle.

➤ Further installation, see Section 8.3 page 53.

### 8.2.2 Under-slung air suspension (trailing arm under the axle)

SLU - ALU - DLU

#### Clamping of trailing arm without tracking plate or with centring bolt or tracking plate under the trailing arm

[22] Place the axle spring seats (1026, 1027) in the correct position on the trailing arm (1000) or, where applicable, the catch plate (1012). (Not applicable for welded axle mountings.)

➤ See page 50 for further installation with step [24].

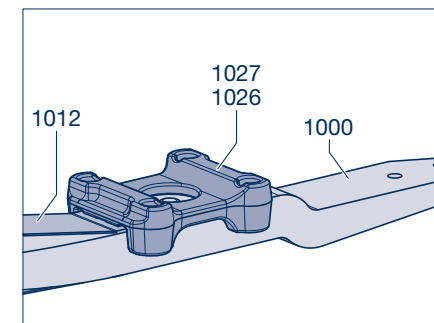

Picture 22

#### Twin leaf trailing arm with centre bolt and tracking plate

[22] For a two-part trailing arm (1000), place the tracking plate (1041) onto the head of the spring screw (1018).

[23] Place the axle spring seats (1026, 1027) onto the tracking plate.

➤ See page 50 for further installation with step [24].

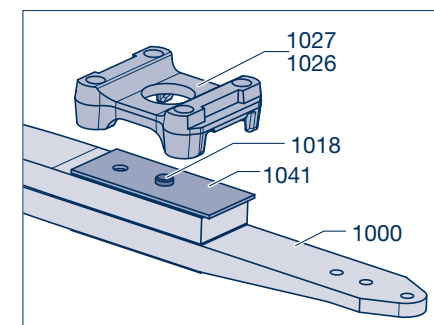

Picture 23

#### Twin leaf trailing arm with centre bolt and centering ring with adjustable support.

[22] Place the centering ring (1042) onto the head of the spring screw (1018). The tracking plate (1041) is not needed.

[23] Place the axle spring seats (1026, 1027) onto the trailing arm (1000) (centering ring).

➤ See page 50 for further installation with step [24].

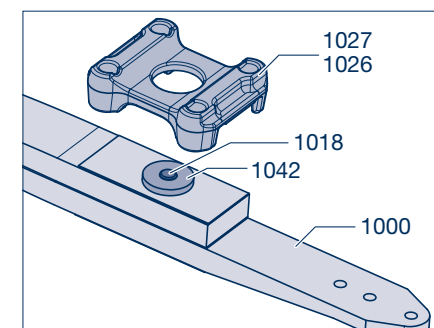

Picture 24

## 8 Dismantling and assembly of trailing arm

### DLU version

- [22] Insert the centering bolt (1040) in the hole of the trailing arm (1000) / catch plate (1012).
- [23] Position the axle spring seats (1026, 1027) on the trailing arm (centering plate) in such a way that the centering bolt is situated in the designated bore hole in the axle spring seat.

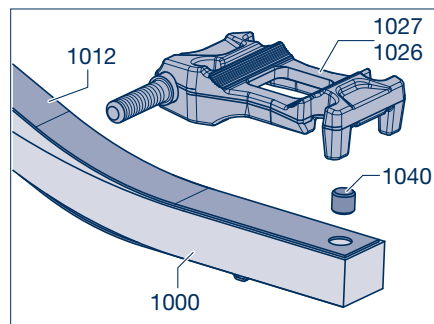

Picture 25

- [24] From below, push the trailing arm (1000) with axle spring seats (1026, 1027), and where applicable the tracking plate (1041) or centering ring (1042), against the axle beam.

For mounting U-bolt from bottom to top, continue with step [25] page 52.

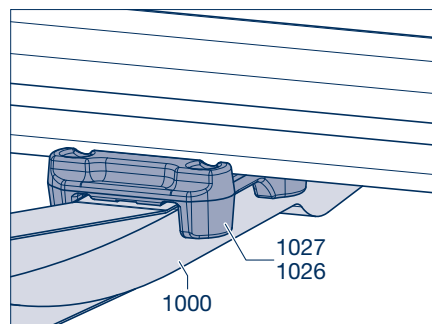

Picture 26

### U-bolt mounting from top to bottom

- [25] Place the segment plate (1035) or axle spring seats (1024) on the centring frame (25) of the axle beam. (Not applicable for welded axle mounting.)
- [26] Insert U-bolt / hexagon bolts from above until they are resting on the segment plate or axle spring seats. Depending on the version, the U-bolts are mounted in front of / behind or alongside the axle beam.

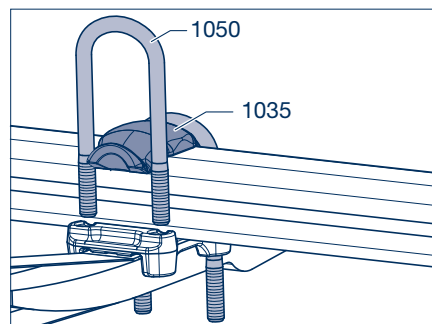

Picture 27

- [27a] For the clamping of a trailing arm with centering bolt on the tracking plate (1041), insert the centering bolt into the bore hole for the trailing arm / catch plate.
- [27b] For the clamping of a trailing arm with centering bolt (1040), insert the centering bolt into the bore hole in the spring plate (1032, 1033).
- [27c] For the clamping of a trailing arm with two tracking plates with centering bolts (1041), insert a bolt into each bore hole of the trailing arm / catch plate and one into the bore hole in the spring plate.

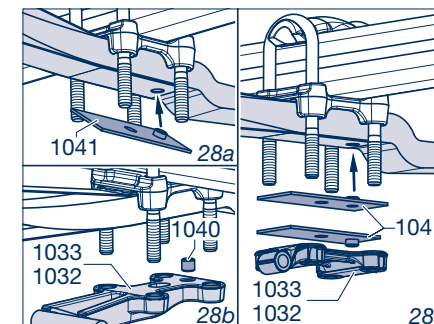

Picture 28

- [28] Slide the spring plate (1032, 1033) onto the U-bolt (1050) from below. Attach new washers (1055).
- [29] Lightly grease the threads of the new U-bolts (1050) / hexagon screws (1053) and the nut contact area.
- [30] Screw the new lock nuts (1057, SW 32) (1330, SW 36) by hand on the U-bolt / hexagon bolts (1053).

Further installation, see Section 8.3 page 53.

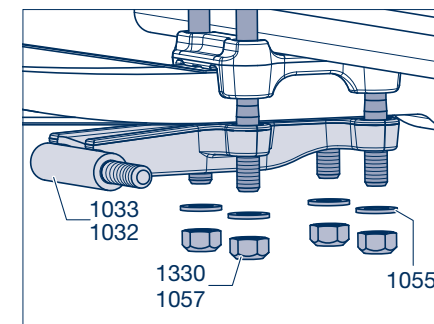

Picture 29

### U-bolt mounting from top to bottom

#### DLU version:

- [25] With offset in the direction of the axle centre, place the conical axle spring seats (1035) on the centring frame (25) of the axle beam.
- [26] Position the U-bolt through the lower axle spring seats (1026, 1027) until the U-bolt is resting on the upper axle spring seats (1035).

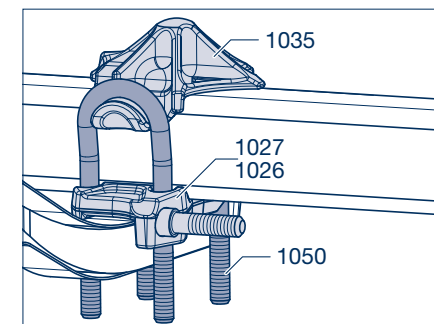

Picture 30

## 8 Dismantling and assembly of trailing arm

- [27] Place the spring plate (1032, 1033) on the U-bolt (1050).
- [28] Attach the new washers (1055).
- [29] Lightly grease the threads of the new U-bolts (1050) / hexagon screws (1053) and the nut contact area.
- [30] Screw the new lock nuts (1057, SW 32) by hand onto the U-bolt.

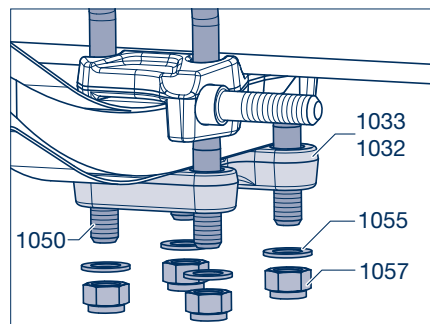

Picture 31

### U-bolt mounting from bottom to top

- [25] From below, push the two U-bolts through the axle spring seats (1026, 1027).
- [26] Insert the segment plate (1035) between the trailing arm (1000) and U-bolt and push in until in contact with the trailing arm.
- [27] Place the spring plate (1032, 1033) onto the U-bolt and centre on the centering frame (25).

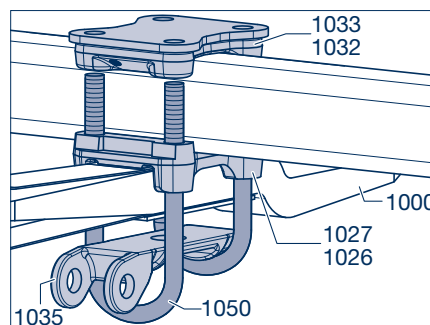

Picture 32

- [28] Attach the new discs (1055).
- [29] Lightly grease the threads of the new U-bolts (1050) and the nut contact area.
- [30] Screw the new lock nuts (1057, SW 32) (1330, SW 36) by hand onto the U-bolt (1050).

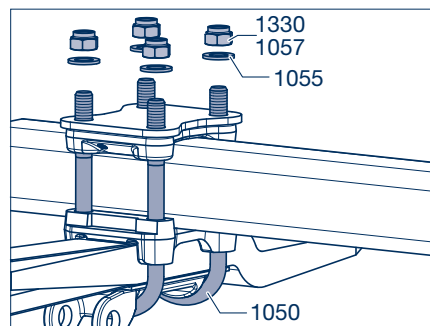

Picture 33

### 8.3 Over-slung air suspension

- [31] For each U-bolt (1050) / hexagon screw (1053), always evenly tighten lock nuts (1057, SW 32) (1330, SW 36) - until all parts are in uniform contact. The axle spring seats (1026, 1027) and segments (1035) should only rest just within the radii of the axle beam (Picture 34, arrows).



**Repair guide!**  
Do not introduce uneven tension by using an incorrect tightening sequence.



**Repair guide!**  
For rigid supports the lock nuts are only tightened to the specified torque after tracking (see Section 16).

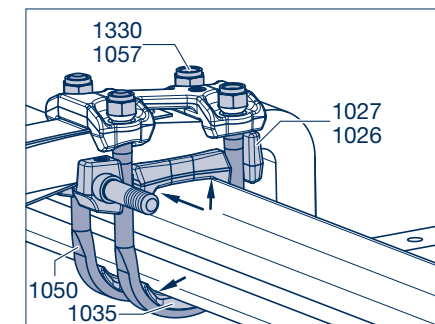

Picture 34

In air suspension with an adjustable hanger bracket (1511), the U-bolts (1050) can be tightened immediately.

- [32] Using a torque wrench, tighten the lock nuts (1057, SW 32) (1330, SW 36) diagonally across in the sequence 1-2-3-4 (see picture 35).

AL / SL / O: Working on alternate lock nuts (surplat 36) and in several stages, tighten the lock nuts (on one U-bolt at a time) to the following tightening torque:  
M 24 M = **650 Nm** (605 - 715 Nm)

AL II: Tighten all lock nuts (SW 32) to a tightening torque of 200 Nm, then to 300 Nm, 450 Nm and 550 Nm.

As the last step, turn all lock nuts through a further 90°.



**Repair guide!**  
Ensure the amount of thread below the U-bolt lock nuts is the same! The spring bolts (1154) must be movable in the spring eyes of the hanger bracket (1511), otherwise the fixture must be corrected by loosening and renewed tightening of the spring U-bolts (1050).

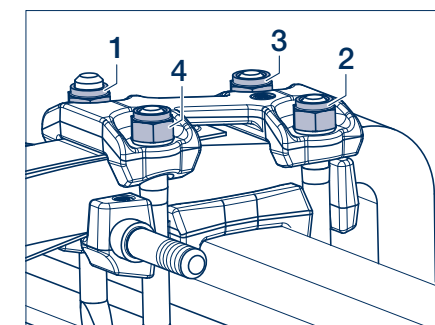

Picture 35

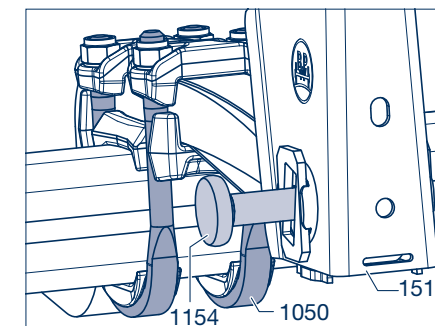

Picture 36

## 8 Dismantling and assembly of trailing arm

### Non-adjustable hanger bracket:

[33a] Push washers (1165) onto the spring bolts (1154), screw on new lock nuts (1168, SW 46) and tighten to the specified torque of:

Hanger brackets from 08/2001:  
M 30 (SW 46) M = **900 Nm** (840 - 990 Nm)

Hanger brackets up to 07/2001:  
M 30 (SW 46) M = **750 Nm** (700 - 825 Nm)

Channel crossmember:  
M 30 (SW 46) M = **900 Nm** (840 - 990 Nm)

 For further installation, see step [34].

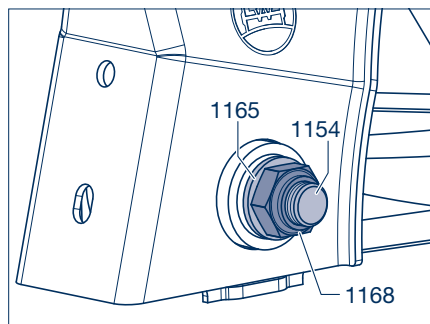

Picture 37

### Adjustable hanger bracket:

[33b] Fit connecting link discs (1161), washer (1165) and new lock nut (1168). The bevels of the connecting link discs must be flushed with one another and engaged in the mouth of the hanger bracket on both sides.



**Repair guide!**  
Do not tighten the lock nuts until secure!

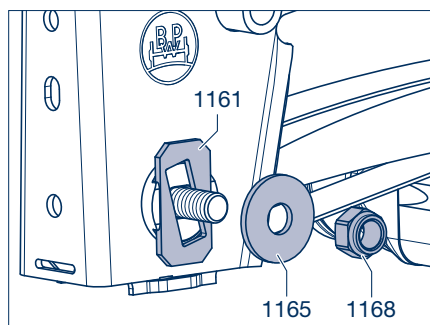

Picture 38

[34] Clean the contact area of the air bag (1200) and the trailing arm (1000).

[35] Position the air bag on the trailing arm.

### Air bags with central bolt connection

[36a] Screw in M 16 locking bolt (1224, SW 22) and tighten to specified torque of M = 300 Nm.

 Airlight Direct is not required for air suspension.

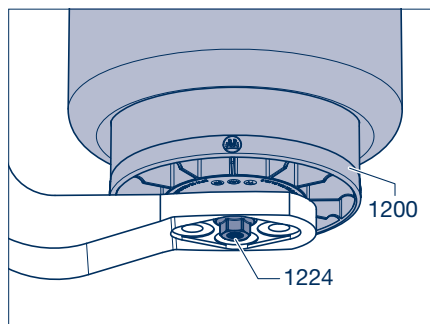

Picture 39

### Air bag with universal and steel plate

[36b] Assemble M 16 locking bolt (1224, SW 22) and tighten to specified torque of M = 230 - 300 Nm.

 If the hex. head bolt (1222, SW 22) is loosened during dis-assembly, check to ensure it is tightened to specified torque of M = 230 Nm.

 Airlight Direct is not required for air suspension.

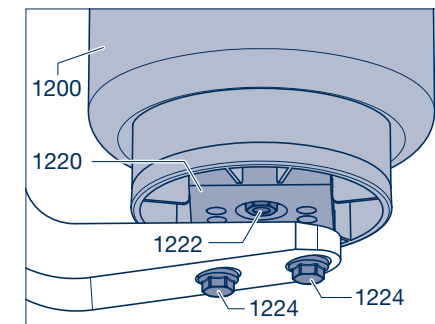

Picture 40

[37] Fit shock absorber (1300), see chapter 11.

[38] Fit U-stabiliser, see chapter 9.2.

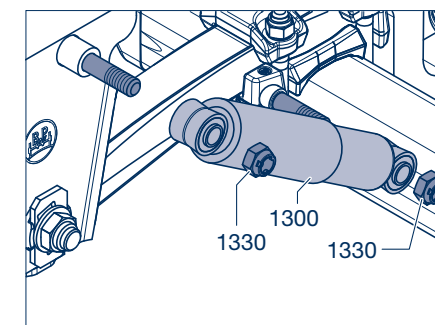

Picture 41

## 8 Dismantling and assembly of trailing arm

### 8.4 Change steel / rubber / steel bushes

#### Extraction

[38] Remove the trailing arm (1000).

[39] Set up a trailing arm under a press. Pay close attention to the vertical position of the bush (1005) and the necessary clearance under the trailing arm.

[40] Insert the insertion and extraction tool (driving mandrel) in the bush of the trailing arm.

BPW number:  
 Ø spring bolt 24 mm: 03.084.37.11.0  
 Ø spring bolt 30 mm: 03.084.37.10.0

[41] Push the bush out of the trailing arm.

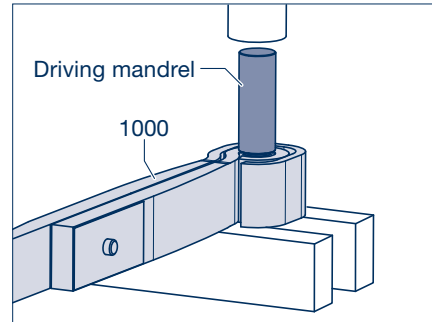

Picture 42

#### Pressing-in

[42] Align the new bush (1005) centrally over the trailing arm eye.

[43] Insert the driving mandrel into the steel bush and push in with a press.



**Repair guide!**  
 After re-inserting in a uniform overhang must be present on both sides (picture 44).

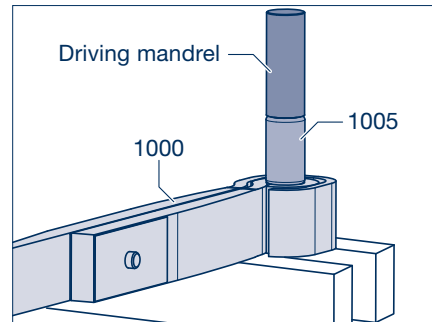

Picture 43

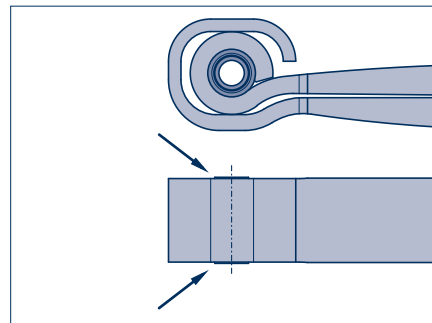

Picture 44

## Dismantling and assembly of U-stabiliser 9

### 9.1 Dismantling U-stabiliser

[1] Unscrew locking nuts (1637, SW 17) from the securing bolts (1645) of the shaped plate (1642).

[2] Remove securing bolts.

[3] Detach shaped plate (1642) and half bushes with seal (1641).

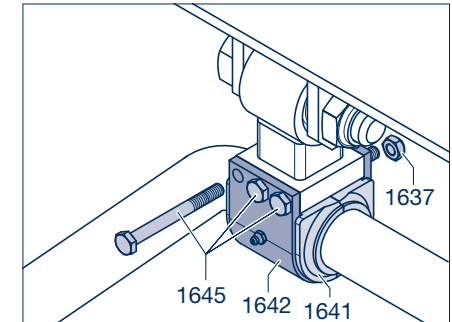

Picture 1

[4] Unscrew locking nuts (1168, SW 46) from the securing bolts (1156) at the spring plates (1032, 1033) and remove securing bolts.

[5] Remove U-stabiliser (1815).

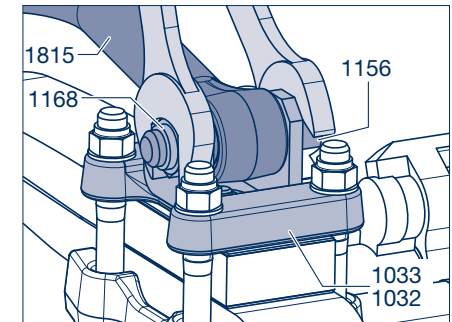

Picture 2

[6] Check rubber-steel bushes (1817) in the anti-roll bar (U-shape) (1815) for wear and, if necessary, replace using an insertion and retraction tool (BPW No. 14.825.11744.); see steps [7] - [13].

➡ Continue with step [14].

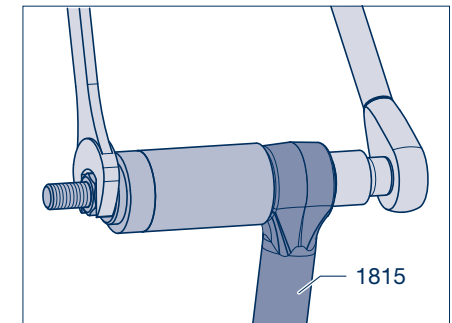

Picture 3

## 9 Dismantling and assembly of U-stabiliser

- [7] Insert screw (1) with disc (2) into the rubber-steel bush (1817).
- [8] Position the tube (3) and tappet (4). Unscrew the nut (5) with a spring washer (6).
- [9] Pull out the rubber-steel bush (1817).

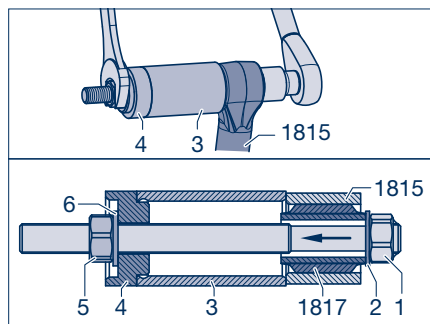

Picture 4

- [10] Coat the new rubber-steel bush (1817) on the outside with soapy water and push it into the tube (3).
- [11] Position the tube in such a way that the inner annular groove (arrow) is on the stabiliser eye.
- [12] Insert screw (1) with washer (2).
- [13] Position tappet (4), screw on the nut (5) including spring washer (6) and set tight the rubber-steel bush (1817) in the stabiliser eye (1815).

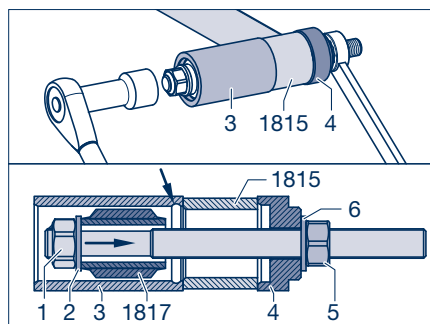

Picture 5



### Repair guide!

When using a press, the rubber-steel bush can be pressed in with assembly tool:

15.002.19433 for bush Ø 52,6 mm  
15.003.19433 for bush Ø 60 mm  
(see page 8).



### Repair guide!

The same projecting end must exist on both sides.

- [14] If necessary, remove bracket (1820) for U-stabiliser by unscrewing locking nut (116, SW 46) of securing bolt (1156), withdrawing securing bolt and remove bracket.
- [15] Examine bonded rubber bush (1817 in bracket for signs of wear, replace if necessary with assembly tool (BPW No. 14 825.11744) or remove and re-insert using a press.

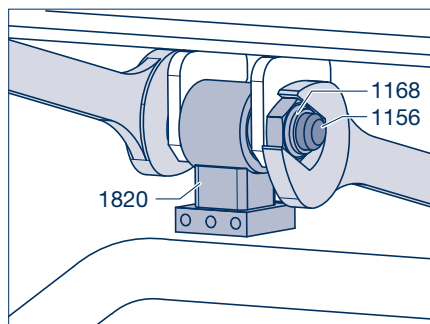

Picture 6

## 9.2 Assembly of U-stabiliser



**Note:**  
The surface of the U-stabiliser (1815) in the area of the bushes must be free of rust.

- [16] If demounted, refit retainer (1820) for U-stabiliser and screw new lock nuts (1168, SW 46) onto the hexagon screws (1156) by hand. Do not tighten.

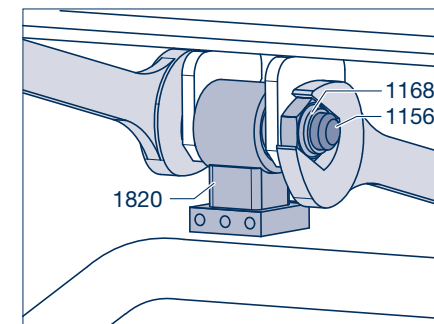

Picture 7

- [17] Fit U-stabiliser (1815) onto the spring plates (1032, 1033) and insert securing bolts (1156).

- [18] Screw on new lock nuts (1168, SW 46). Do not tighten.

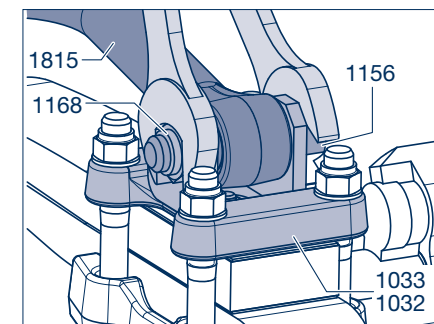

Picture 8

- [19] Examine bush halves (1641) and seals for signs of wear, fit new parts, if necessary.

- [20] Smear bush halves with BPW special longlife grease ECO-Li<sup>plus</sup>.

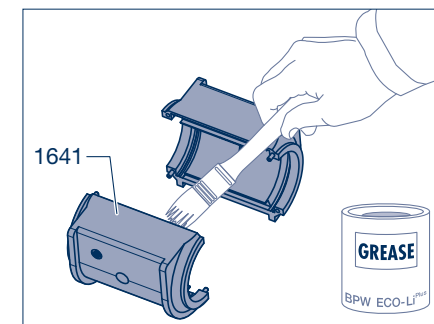

Picture 9

## 9 Dismantling and assembly of U-stabiliser

[21] Fit seals onto U-stabiliser and secure.

[22] Fit bush halves (1641) so that the seals are located in the grooves (arrow).

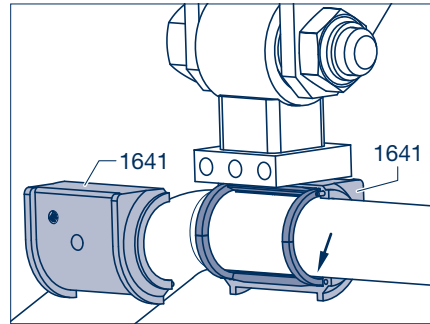

Picture 10

[23] Fit shaped plate (1642) onto the bush halves (1641).

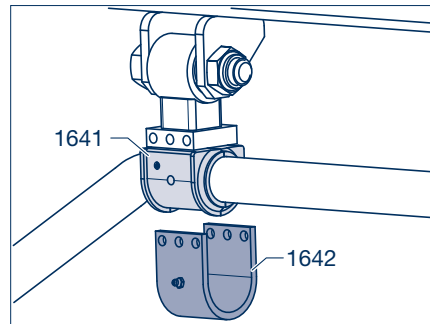

Picture 11

[24] Insert securing bolts (1645) through the shaped plate (1642), screw on new locking nuts (1637, SW 17) and tighten to the specified torque of 53 Nm.

[25] Lubricate the bearing with BPW special longlife grease ECO-Li<sup>plus</sup> via the lubrication nipple (1643).

[26] Tighten the lock nuts (1168) of the hexagon bolts (1156, pictures 8 and 12) to the specified torque of 750 Nm (700 - 825 Nm).

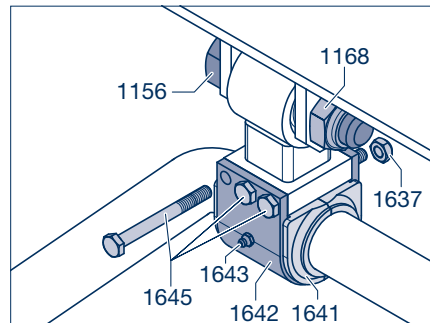

Picture 12

## Dismantling and assembly of air bags 10

### 10.1 Dismantling air bag

[1] Inflate air bags (1200) as much as possible using the rotary slide valve/pilot valve.

[2] Support vehicle to prevent accidents, e.g. place suitable spacer between vehicle frame and trailing arm (1000).

[3] Deflate the air bags.

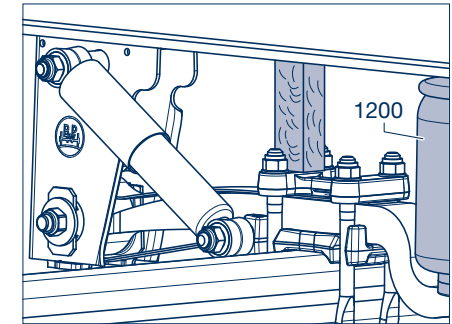

Picture 1

### Air bags with central bolt connection

[4] Remove locking bolt (1224, SW 22).

➡ Continue with work step [5].

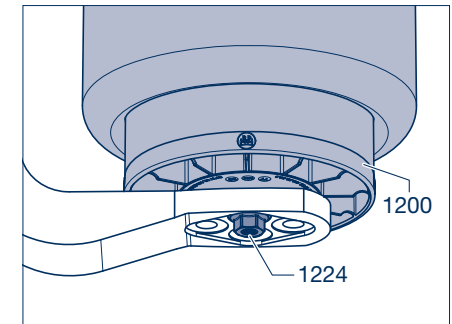

Picture 2

### Air bag with universal plate or steel piston

[4] If the air bag (1200) is to be disassembled after being removed, slacken centre hexagon bolt (1222, SW 22) to facilitate disassembly.

Remove locking bolt (1224, SW 22).



#### Repair guide!

If the hexagon bolt (1222) is above the trailing arm, it cannot be slackened until the air bag has been removed.

➡ Continue with work step [5].

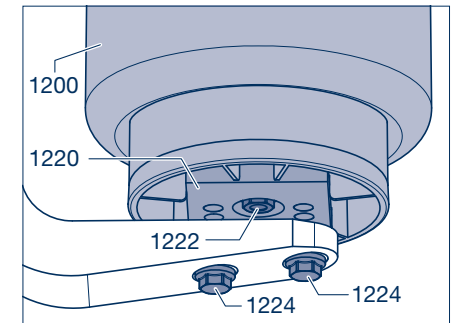

Picture 3

## 10 Dismantling and assembly of air bags

### Combi Air bag

- [4] Remove locking bolt (1224, SW 22). Remove the support (1212) from the trailing arm (1000).

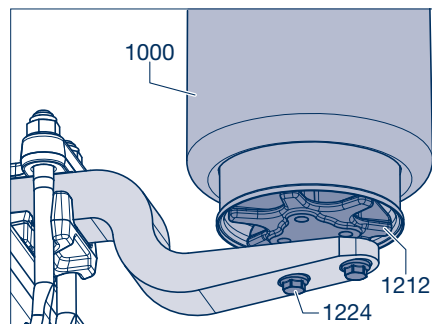

Picture 4

- [5] Unscrew union nut (2) from fitting (1) and detach air hose (3) from fitting.

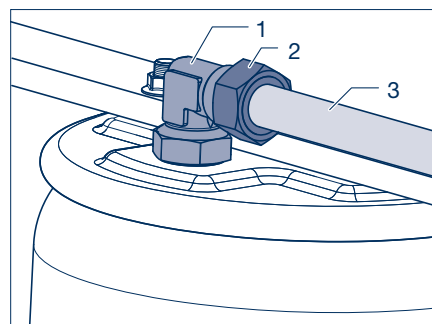

Picture 5

- [6] Unscrew both lock nuts (1240, SW 17) from the bolts.



#### Repair guide!

The second nut may be located in the frame.

For aluminium frames, the upper mounting can comprise of spring washers (1243) and shouldered nuts (1244, SW 30).

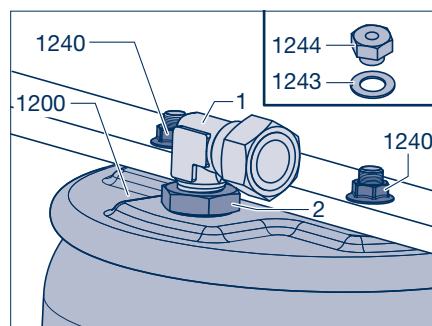

Picture 6

- [7] If necessary loosen counter nut (2) on fitting (1) and unscrew fitting from air bag (1200).

- [8] Remove air bags (1200).

### 10.2 Assembly air bag

- [9] Push thrust ring (3) with smooth face first over the thread of the coupling (1), then push on new O-ring (4).

- [10] Insert coupling into the air bag but do not yet tighten the locking nut (2).

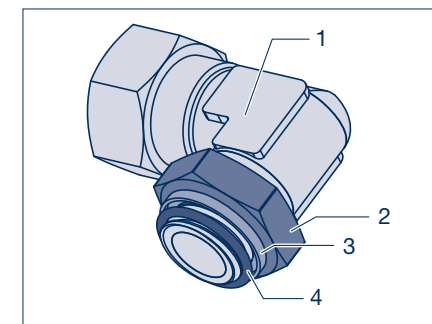

Picture 7

- [11] Clean the contact area of the air bag and the trailing arm (1000).

#### Air bags with central bolt connection

- [12] Position air bag (1200) on trailing arm (1000).

- [13] Screw in M 16 locking bolt (1224, SW 22) and tighten to specified torque of M = 300 Nm.

- Continue with work step [14].

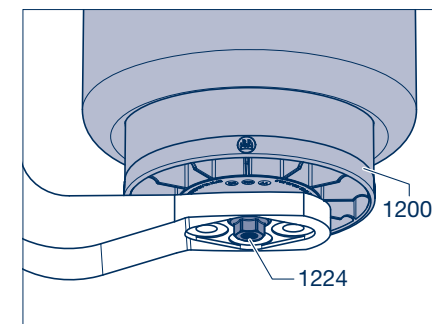

Picture 8

#### Air bag with universal plate or steel piston

- [12] Place the air bag (1200) on the trailing arm (1000).

- [13] Screw in locking bolts M 16 (1224, SW 22) and tighten to the specified torque of 230 - 300 Nm.

- If the hex. head bolt (1222, SW 22) is loosened during dis-assembly, check to ensure it is tightened to specified torque of M = 230 Nm.

- Continue with work step [14].

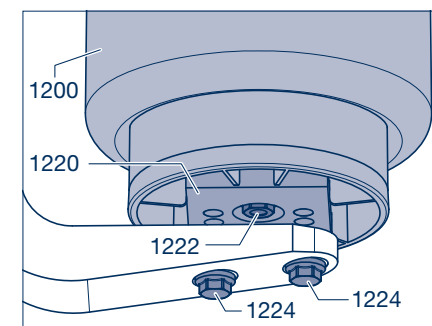

Picture 9



## 10 Dismantling and assembly of air bags

### Combi Air bag

- [12] Place the support (1212) in the correct position on the trailing arm (1030).
- [13] Screw in locking bolts M 16 (1224, SW 22) and tighten to the specified torque of 230 - 300 Nm.

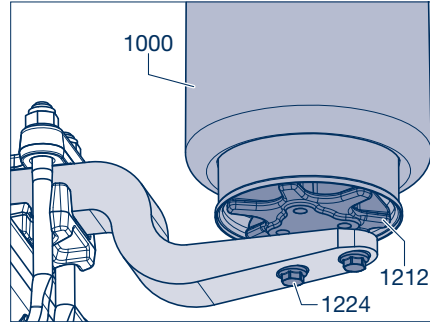

Picture 10

- [14] Inflate air bags (1200) slightly, while simultaneously inserting the two bolts for the top plate into the holes provided for this purpose on the vehicle frame.
- [15] Screw both locking nuts (1240, SW 17) onto the bolts and tighten to the specified torque of 66 Nm.



#### Repair guide!

The second nut may be located in the frame.

For aluminium frames, the upper mounting can comprise spring washers (1243) and shouldered nuts (1244, SW 30).

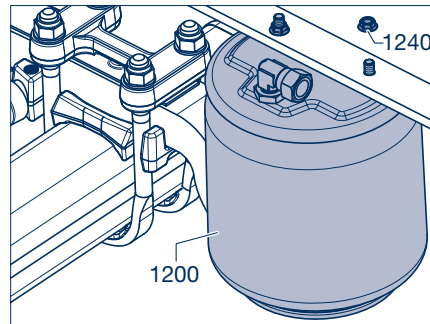

Picture 11

- [16] Screw union nut (2) of the pressure hose (3) to the coupling (1), then tighten the locking nut (4).
- [17] Check that compressed air system operates properly and is free of leaks.

- 🔧 Air bag with pivot connection, see page 66.
- 🔧 Air bag with steel piston, see page 67.
- 🔧 Combi air bag, see page 68.
- 🔧 Airlight Direct air bag, see page 69.

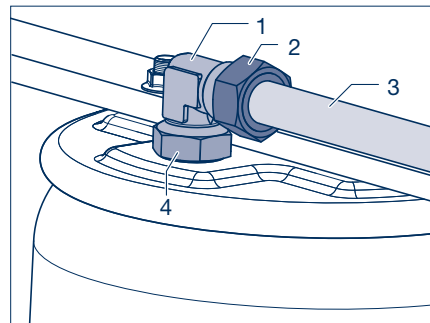

Picture 12

### 10.3 Dis-assembling and assembling air bags with universal plate

#### Dis-assembly

- [18] Remove air bags, see chapter 10.1.
- [19] Inflate air bag using compressed air until it has completely rolled off the piston.
- [20] Use an impact driver to unscrew and remove the locking screw (1222, SW 22).

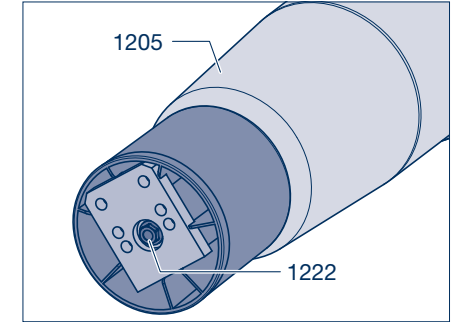

Picture 13

- [21] Remove washer (1220) and plastic piston (1210).
- [22] Remove threaded sleeve (1215, SW 24).

#### Assembly

- [23] Tighten threaded sleeve (1215, SW 24) on air bag (1205) to torque of 130 Nm.

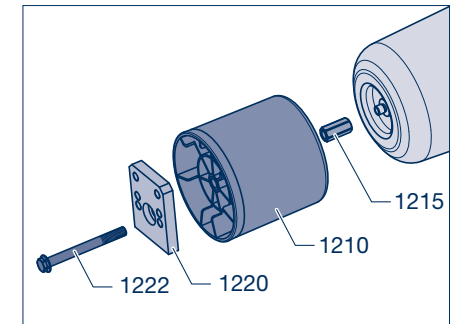

Picture 14

- [24] Position plate (1220) in plastic piston (1210) and tighten locking bolt (1222, SW 22) on to threaded sleeve (1215) loosely.
- [25] Align mounting points with one another so that air bag is not turned to wrong position after installation.
- [26] Tighten locking bolt (1222, SW 22) to specified torque of 230 - 300 Nm.

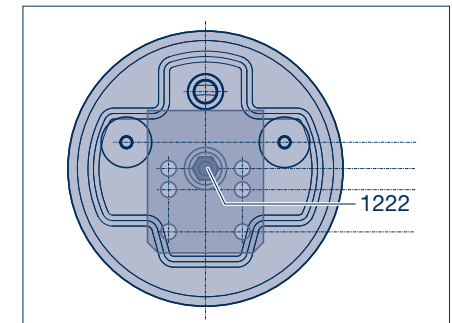

Picture 15

## 10 Dismantling and assembly of air bags

### 10.4 Dis-assembling and assembling air bags with central bolt connection

#### Disassembly

- [18] Remove air bag (1200), see chapter 10.1.
- [19] Feed compressed air in to the port for air connection until air bags (1205) are completely extended.
- [20] Pull plastic piston (1210) off of bolt (1215).

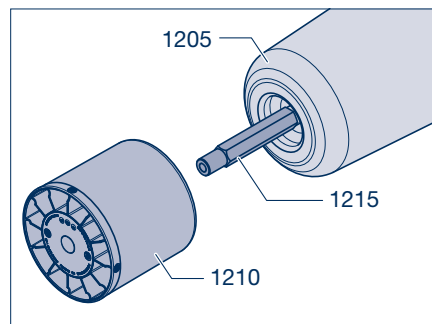

Picture 16

- [21] Remove bolt (1215, SW 32) off the air bag.

#### Assembly

- [22] Tighten bolts (1215, SW 32) on air bag (1205) to torque of 130 Nm.
- [23] Install plastic piston (1210) on bolt (1215).

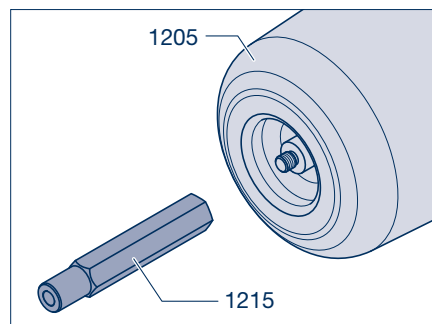

Picture 17

### 10.5 Disassemble and reassemble air bag with steel piston

#### Disassembly

- [18] Remove air bag (1200), see chapter 10.1.
- [19] Feed compressed air in to the port for air connection until air bags (1205) are completely extended.
- [20] Unscrew locking screw (1222 SW 22) with an impact wrench and remove the disc (1220) from the spring piston (1210).
- [21] Unscrew the square bolt (1215) with an impact wrench and detach from the air bag (1205) with the spring piston (1210), where applicable with ring (1216).

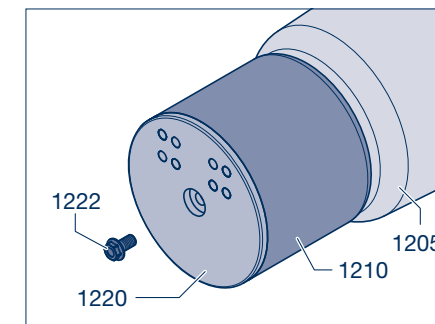

Picture 18

#### Assembly

- [22] Place piston (1210) on air bag (1205). Screw in square bolt (1215), including ring (1216) where applicable and tighten to the prescribed torque of 130 Nm.
- [23] Place the disc (1220) on the spring piston (1210) and tighten the locking screw (1222, SW 22).

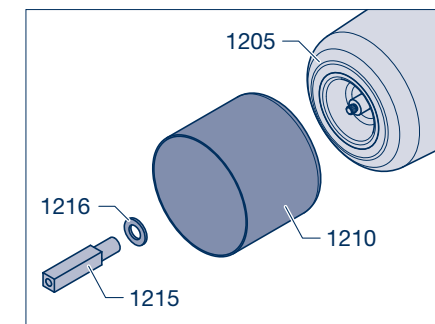

Picture 19

-  Ensure the bolt is of the correct length.

## 10 Dismantling and assembly of air bags

### 10.6 Dis-assembling and assembling air bags with split piston

#### Dis-assembly

- [18] Remove air bag (1200), see chapter 10.1.
- [19] Feed compressed air in to the port for air connection until air bag (1205) is completely extended.
- [20] Loosen nut with hexagonal recess (1218, SW 19) using impact wrench and unscrew.

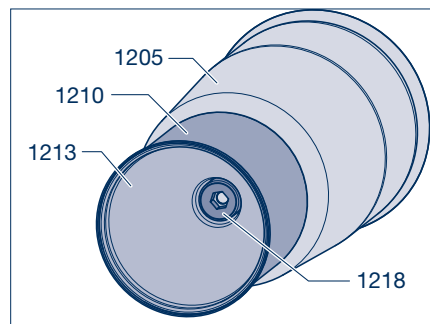

Picture 20

- [21] It is then possible to remove the two pistons (1210, 1213).

#### Assembly

- [22] Install piston (1213) in piston (1210).

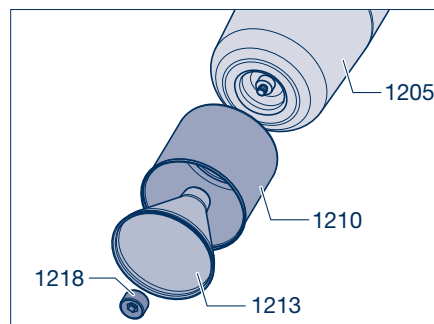

Picture 21

- [23] Coat threads (arrow) on air bag (1205) with thread-locking adhesive, e.g. Loctite.

- [24] Assemble the pistons on to air bellows with nut (1218, SW 19).  
Tightening torque:  $M = 130 \text{ Nm}$

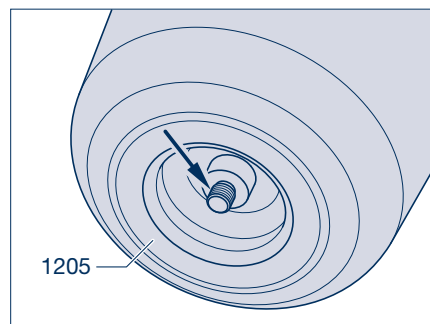

Picture 22

### 10.7 Disassemble and reassemble Airlight Direct air bag

#### Dis-assembly

- [18] Remove air bag (1200), see chapter 10.1.
- [19] Feed compressed air in to the port for air connection until air bag (1205) is completely extended.
- [20] Unscrew and remove the bolt with internal hexagonal socket (1219, SW 8) and remove it from the piston (1213) along with the shaped part (1218).
- [21] Detach the spring piston support (1210) together with the spring piston (1213).

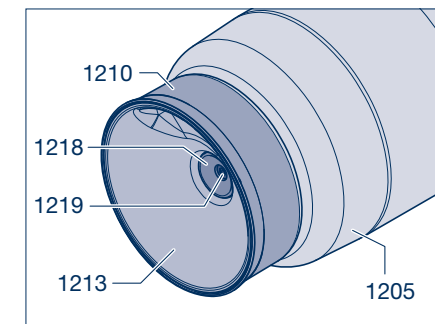

Picture 23

#### Assembly

- [22] Insert the spring piston (1213) with the indentation in the notch of the spring piston (1210).
- [23] Screw together the shaped part (1218), spring piston (1213) and spring piston support (1210) onto the air bag (1205) with the screw (1219).

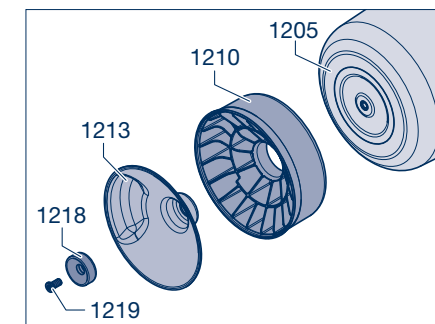

Picture 24



#### Repair guide!

Before tightening the locking screw (1219), line up the upper attachment points in parallel with the recess in the piston (1213) (picture 25/arrow), so that the air bag will not be tilted after it is installed.

- [24] Tighten the locking screw M 12 (1219, SW 8) to a tightening torque of 80 Nm.

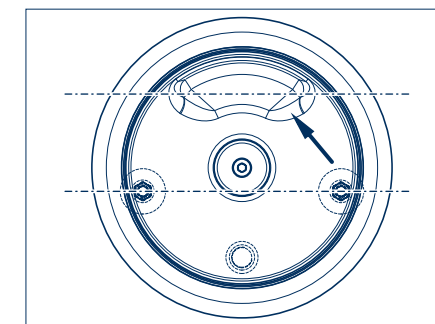

Picture 25

# 11 Dismantling and assembly of shock absorbers

## Dis-assembly

- [1] Unscrew locking nuts (1330, SW 36) from the top and bottom threaded bolts (1310) and securing bolts (1315, 1324).
- [2] Remove the shock absorber (1300).

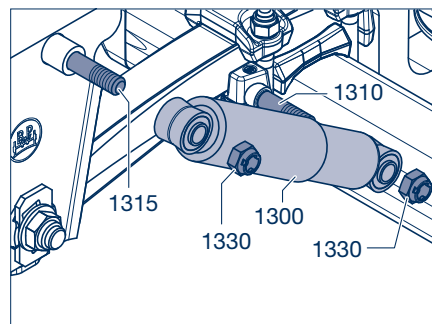

Picture 1

-  For shock absorber attachment between plates, pull out the mounting screw (1315, 1324), and remove the shock absorber (1300) and, where appropriate, the distance rings (1318).

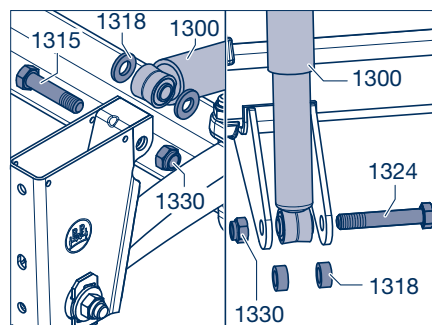

Picture 2

## Assembly



### Repair guide!

- Replace shock absorbers in pairs or per axle only.

- Install shock absorber with the protective sleeve facing up.

- Smear threaded bolts or fastening screws with grease at fixing points for shock absorbers.

- In steel hanger brackets with a tube and screw, grease the M 24 screw and install it.

- [3] On threaded bolts with thread at both ends (M 30 / M 24, 1324), install spacer sleeve (1327) or the U-stabiliser.  
Refit locking nut M 30 (1168, SW 46) and tighten to the specified torque of **750 Nm** (700 - 825 Nm).

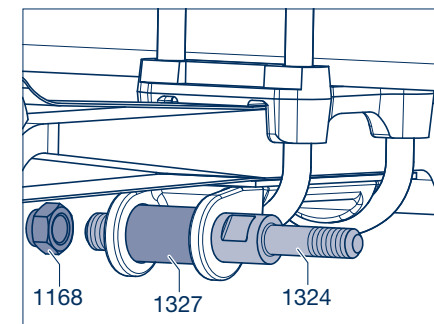

Picture 3

- [4] Lightly grease the threads of the threaded bolt (1310) and the mounting screws (1315, 1324).
- [5] Push shock absorber (1300) onto the threaded bolt(s).

In the case of a shock absorber fastening between plates, push in fastening screw (1315, 1324), inserting spacer sleeves or washers (1318, figure 2) where required in the process.



### Repair guide!

For aluminium supports, a steel washer (1318) should be fitted for all contact areas (Picture 5).

When using PDC shock absorbers, a distance washer as well as a flat lock nut (1318) must be used (1330) between each support or axle spring seat and the PDC, respectively.

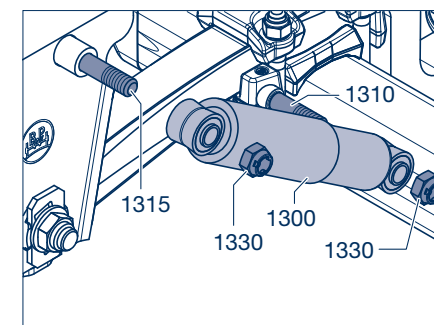

Picture 4

- [6] Fit new locking nuts M 24 (1330, SW 36) and tighten to the specified torque.

Tightening torque:

Steel hanger bracket M = **420 Nm** (390 - 460 Nm)

Alu. hanger bracket M = **320 Nm** (300 - 350 Nm)

Stainless steel hanger brackets

M = **320 Nm** (300 - 350 Nm)

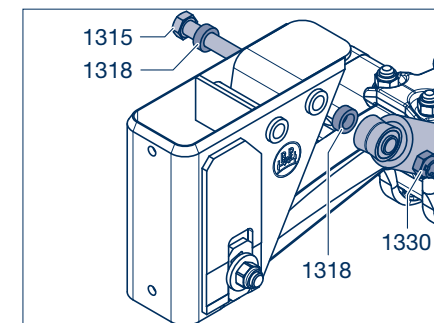

Picture 5

# 11 Dismantling and assembly of shock absorbers

## 11.1 Replacing bushes in shock absorber

### Removal

- [1] Remove shock absorber (1300).
- [2] Align shock absorber eye beneath press and press out steel bush (1303) with suitable tool.
- [3] Then press out rubber bush (1304).



**Repair guide!**  
When pressing out, do not damage shock absorber or shock absorber eye.

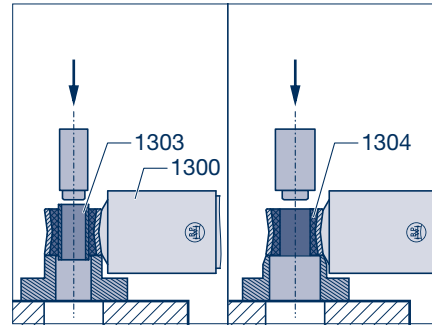

Picture 6

### Installation

- [4] Coat rubber bush (1304) and steel bush (1303) with 50% soap solution.
- [5] Press rubber bush in to stop in shock absorber eye.
- [6] Position steel bush (1303) on a suitable mandrel.
- [7] Turn shock absorber 180°. Press in steel bush with drift punch.

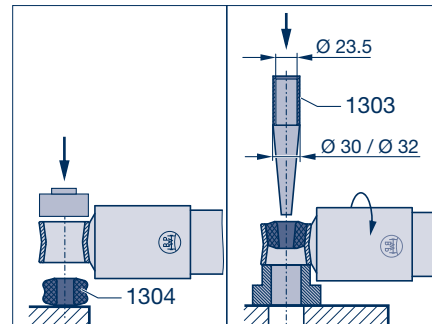

Picture 7



**Repair guide!**  
After replacing the rubber and steel bushes (1303, 1304) the protrusion on both sides of the shock absorber eye must be equal.

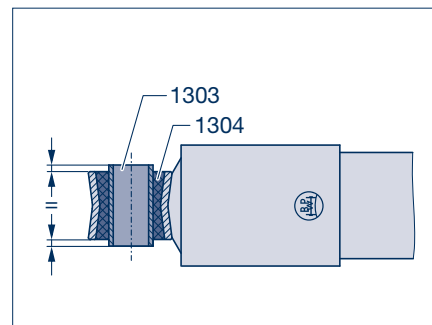

Picture 8

# Dismantling and assembly check straps 12

### Dismantling (at threaded bolt)

- [1] Dismantle tension spring (1375), if fitted.
- [2] Release lock of securing nuts (1370) and unscrew, remove shaped plate (1368) and check strap (1360) from the threaded bolts (1362).
- [3] In the case of longer bolts, then remove spacer sleeves (1365).

### Assembly (to threaded pin)

- [4] Push on the distance sleeves (1365), if necessary.
- [5] Place one end of the catch strap (1360) onto a threaded bolt (1362) and guide the other end under the axle between the axle beam and the brake camshaft. Hook in the return spring (1375) and connect to the second threaded bolt with the strap.

- [6] Place shaped plate (1368) in position, screw on securing nut (1370) and tighten.
- [7] After tightening the nuts, bend each corner of the backing plate over the nuts to secure them (arrow).

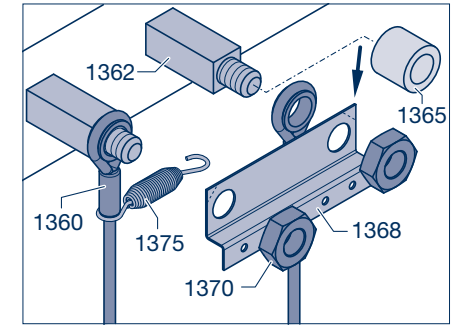

Picture 1

### Dismantling (at split pin bolt)

- [1] Dismantle tension spring (1375), respectively, if fitted. Remove split pin (1371) from the split pin bolt (1362).
- [2] Remove washer (1368), check strap (1360) and washer (1368) from the split pins.
- [3] In the case of longer bolts, then remove spacer sleeves (1365).

### Assembly (to split pin bolt)

- [4] Push on the distance sleeves (1365).
- [5] Fit washers (1368) onto the split pin bolts.
- [6] Fit one end of the check strap (1360) onto a split pin bolt, fit on washer (1368), insert new split pin (1371) and secure by bending over.
- [7] Guide the other end under the axle between the axle beam and the brake camshaft. Hook in the return spring (1375) and attach the strap to the second split pin using the washer and split pin (1362).

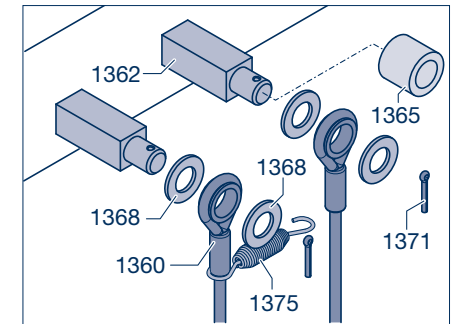

Picture 2

## 13 Dismantling and assembly of axle lift device

### 13.1 Lateral and central axle lift device

- 🔧 Two-side axle lift with adjustable support, AIRLIGHT II series, see page 80.
- 🔧 Two-side axle lift with fixed and adjustable support – SLO / SLM series, see page 84.
- 🔧 Two-side axle lift with adjustable, bolted support – SLO / SLM series, see page 89.

#### Dismantling

- [1] Support axle to prevent accidents and release air from air suspension system.
- [2] Unscrew bottom locking screws or central bolt (1224, SW 22) for lift bags (1200).

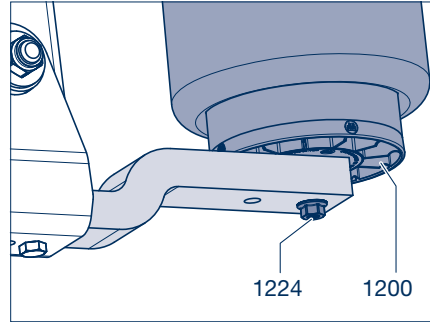

Picture 1

- [3] Remove lock nut (1168, SW 36 / SW 46) from spring bolt (1156).
- [4] Remove washer (1165).
- [5] Secure lift arm (1610) against falling down and drive out spring bolt.



**Caution! RISK OF INJURY**  
Use hoist or have second person help remove lift arm.

- [6] Detach the lifting arm with the bushes (1175, 1180) and, where applicable, the adjusting plates (1161, 1560) and wearing plates (1525). In the centre-mounted lift axle system, remove the tube (1605) from the air spring bracket (Picture 7).

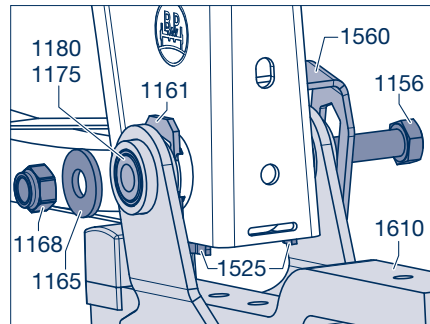

Picture 2

- [7] Unscrew the hexagon screws (1225, SW 22 / SW 24) from the lifting arm (1610) and remove the bracket (1615).
- [8] Check bump stop (1635) for wear and remove where applicable. For 70 mm-wide lifting arms, the hexagon screw (1636, SW 17) must be unscrewed in order to disassemble the bump stop.

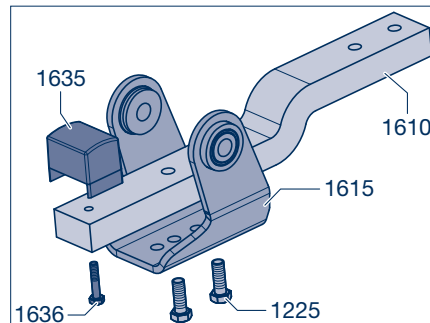

Picture 3

#### Assembly

- 🔧 Clean all parts, check for wear and damage, replace, if necessary.
- [9] Mount the rubber bump stop (1635). For 70 mm-wide lifting arms, tighten the hexagon screw (1636, SW 17) to 25 Nm.
- [10] Screw together the lifting arm (1610) and support (1615) with the two hexagon screws (1225, SW 22 / SW 24) and tighten to a torque of 230 Nm.



**Repair guide!**  
The positioning of the lever arm is dependant on the specific design of the device. Observe the correct location on assembly !

- [11] Position bush (1180) on stepped bush (1175).
- [12] Insert pre-assembled bushes in to lift arm (1630) from inside to outside.

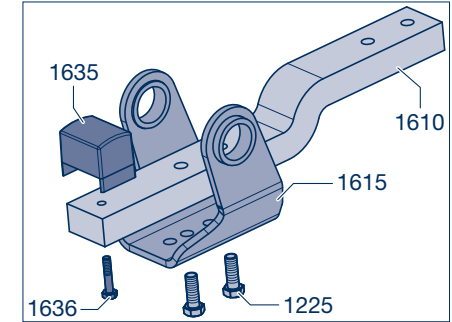

Picture 4

- [13] Lightly grease the spring bolt (1156).



**Caution! RISK OF INJURY**  
When mounting the lifting arm, use a hoist or ask a second person for assistance.

- [14] Prepare a mandrel or dis-used spring bolt.
- 🔧 For the installation of adjustable support with adjusting plate, see page 77.

#### Rigid hanger bracket

- [15] Raise the lifting arm (1610) with the preassembled bushes (1175, 1180) until the bushes are aligned with the steel-rubber-steel bush (1005) in the trailing arm (1000).

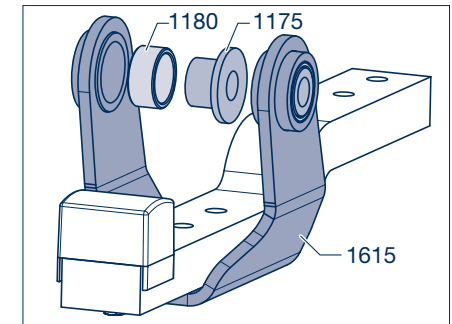

Picture 5

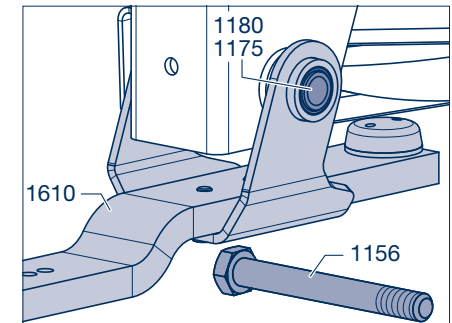

Picture 6

## 13 Dismantling and assembly of axle lift device

- [16] Insert the mandrel or dis-used spring bolt in the trailing arm bushing from the inside outwards.
- [17] For centre-mounted centre lift axles, insert a distance tube (1605) into the air spring bracket (1510).

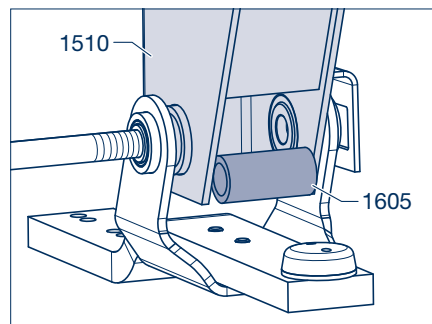

Picture 7

- [18] Insert spring bolt (1156) into the welded torsion protection (1560) on the air spring bracket (1510).
- [19] Slide on the disc (1165).
- [20] Push in the spring bolt to the inside edge of the support bush.

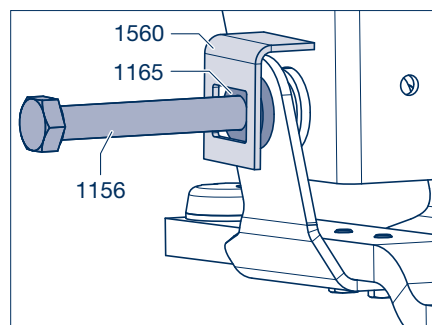

Picture 8

- [21] Mount the loose wearing plate (1525) between support bush and the trailing arm bushing (does not apply for welded wearing plates).
- [22] Insert the spring bolt (1156) and where applicable mount the second wearing plate. Here, the mandrel or dis-used spring bolt will be forced out of the spring pivot bolt bearing.
- [23] Fully insert the spring bolt until the spring bolt head is positioned in the torsion protection (1560).

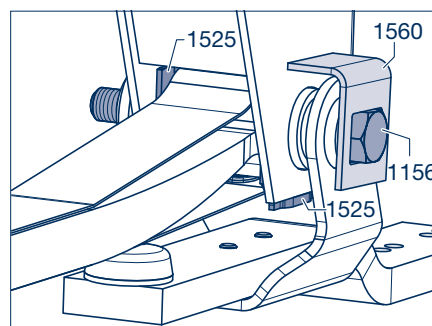

Picture 9

- [24] Slide on the disc (1165). Screw on the lock nut (1168, SW 36 / SW 46) and tighten to the prescribed torque.

Tightening torques:

Air suspension hanger brackets and channel crossmember from 09/2007:  
M 24 (SW 36) M = **650 Nm** (605- 715 Nm)

Hanger brackets from 08/2001:  
M 30 (SW 46) M = **900 Nm** (840 - 990 Nm)

Hanger brackets up to 07/2001:  
M 30 (SW 46) M = **750 Nm** (700 - 825 Nm)

Channel crossmember:  
M 30 (SW 46) M = **900 Nm** (840 - 990 Nm)

 For further installation see step [25], page 79.

### Adjustable hanger bracket

- [14] Attach adjusting plate with anti-rotation lock (1560), position washer (1165) and insert new, lightly greased spring bolt (1156).

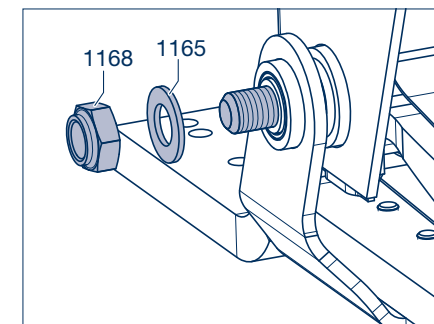

Picture 10

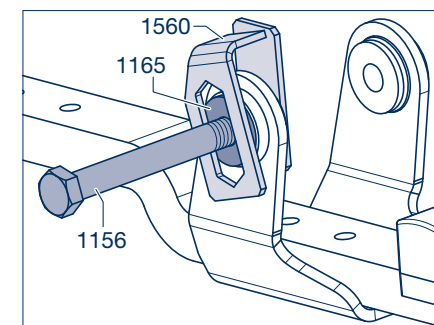

Picture 11

- [15] Raise the pre-assembled lifting arm (1610) until the bushes (1175, 1180) are aligned with the steel-rubber-steel bush (1005) in the trailing arm (1000).
- [16] Push in the spring bolt (1156) to the inside edge of the support bush.

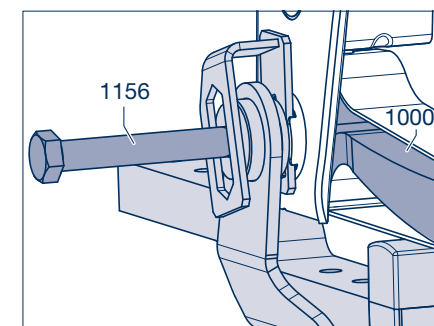

Picture 12

## 13 Dismantling and assembly of axle lift device

- [17] Insert the loose wearing plate (1525) between support bush and the trailing arm bushing (not applicable for welded wearing plates).
- [18] Push in the spring bolt (1156) further and, where applicable, mount the second wearing plate.

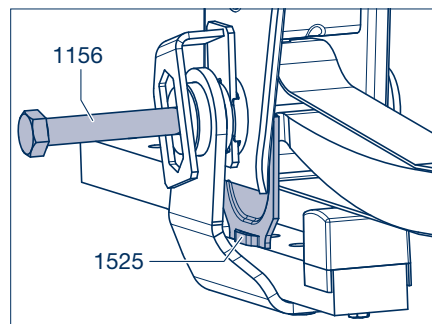

Picture 13

- [19] Install adjusting plate (1161) in correct position between air suspension hanger bracket (1511) and stepped bush (1175). The bevels of the adjusting plates must be aligned with each other and must mesh with the support jaw on both sides.
- [20] Fully insert the spring bolt (1156) until the spring bolt head is positioned in the torsion protection (1560) of the adjusting plate.

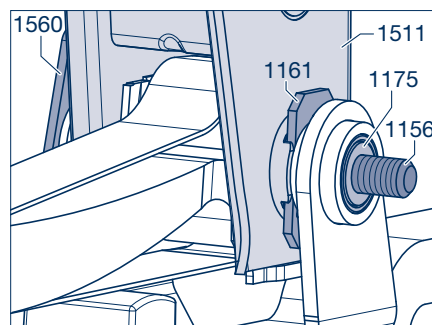

Picture 14

- [21] Attach washer (1165), fit new lock nut (1168).
- [22] Ensure that adjusting plate is correctly seated on anti-rotation lock (arrow) on air suspension hanger bracket.
- [23] Tighten lock nut (1168, SW 36 / SW 46) to the specified torque.

Tightening torque:

Air suspension hanger brackets and channel crossmember from 09/2007:

M 24 (SW 36) M = **650 Nm** (605 - 715 Nm)

Hanger brackets from 08/2001:

M 30 (SW 46) M = **900 Nm** (840 - 990 Nm)

Hanger brackets up to 07/2001:

M 30 (SW 46) M = **750 Nm** (700 - 825 Nm)

Channel crossmember:

M 30 (SW 46) M = **900 Nm** (840 - 990 Nm)

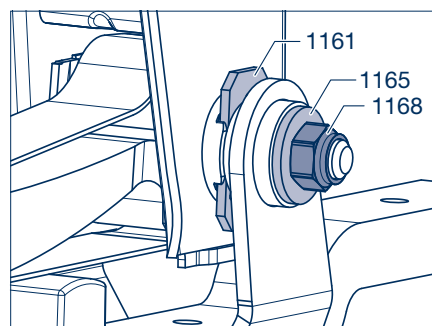

Picture 15

### Fixed and adjustable support

- [25] Secure the lifting arm (1610) to the lift bag (1200) with locking screws or central screw (1224, SW 22).  
Tightening torque: 230 - 300 Nm

Upper securing nuts (1240, SW 17):  
Tightening torque: 66 Nm

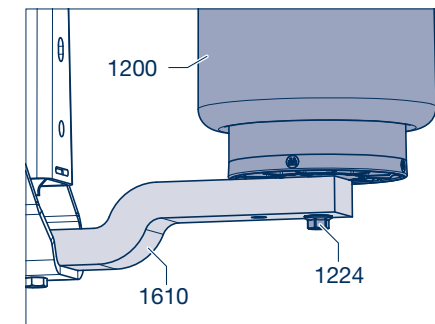

Picture 16

- [26] For clamped versions, check bracket (1600) for tightness and wear.
- [27] For replacement parts or modifications, unscrew the locking nuts (1330) from the U-bolt (1050) and remove the washers (1055).
- [28] Take off bracket with U-bolt and axle spring seats (1024).
- [29] Position the bracket on the axle beam.
- [30] Attach the new U-bolt, attach axle spring seats and mount the new discs and locking nuts.
- [31] Tighten the U-bolt to a torque of **650 Nm** (605 - 715 Nm). Make sure that the U-bolt threads are matched in height.

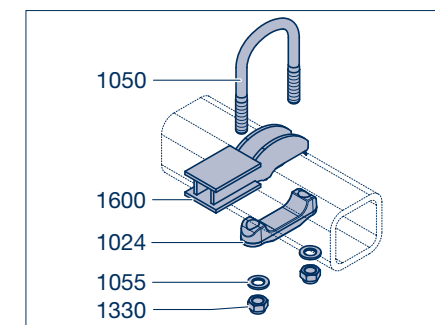

Picture 17



## 13 Dismantling and assembly of axle lift device

### 13.2 Two-side axle lift with adjustable support, trailing arm 70 mm wide

#### Removal

- [32] Support axle to prevent accidents and deflate air suspension.
- [33] Remove the lifting cylinder (1660), to do this unscrew the two lock nuts (1663, SW 24 / SW 30) from the threaded bolts of the lifting cylinder.

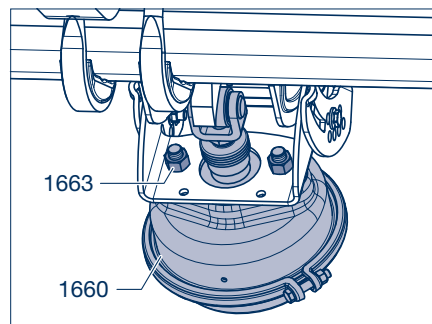

Picture 18

- [34] Unscrew lock nut (1168, SW 36) from spring pivot bolt (1156). Detach the disc (1165).

- [35] Push the spring bolt from the bearing.



#### Caution! RISK OF INJURY

When the spring bolt is pushed out, the axle lift is loosened and can fall out with the wearing plates (1525) and adjusting plates (1161).

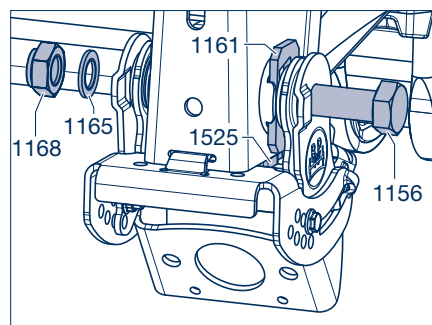

Picture 19

- [36] Remove axle lift with bushes (1175, 1180), adjusting plates (1161) and the wear plates of the supports (1525).

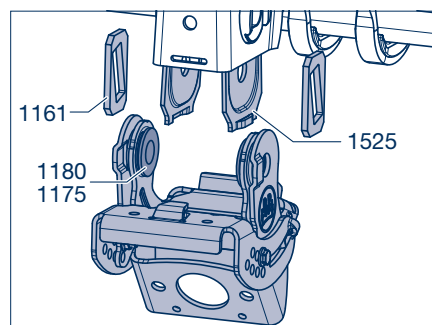

Picture 20

- [37] To replace the bump stop (1620) on the lever (1615), twist the locking nuts (1623, SW 10) of the cylinder head screws (1621).

- [38] Replace the bump stop and mount it on the lever with new cylinder head screws and lock nuts. Tightening torque: 8 Nm

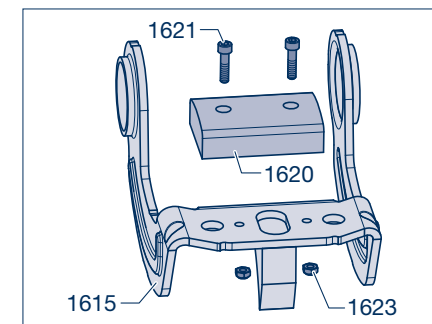

Picture 21

- [39] Make a note of the setting position (arrow) before the replacement of a shaped plate (1610, 1613).

- [40] Twist the lock nut (1636, SW 17) from the locking screw (1635) and disassemble the two formed plates.

#### Assembly

-  Clean all parts, check for wear and damage, replace, if necessary.

- [41] If removed, place the shaped plate (1613) onto the other shaped plate (1610). Here, the moulded nibs must be guided into the notches (arrow).

- [42] Insert the new locking screws (1635) into the previously noted setting position (step [39]) and screw together with the new locking nuts (1636, SW 17). Tightening torque: 75 Nm

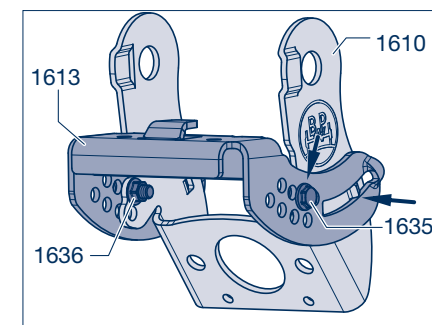

Picture 22

- [43] Place the bush (1180) in the correct position on the graduated bush (1175).

- [44] Insert preassembled bushes in the lever (1615) from the inside outwards.

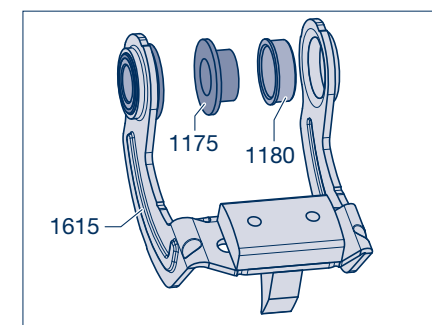

Picture 23

## 13 Dismantling and assembly of axle lift device

- [45] Prepare a mandrel or dis-used spring bolt.
- [46] Insert the lever (1615) in the formed plate (1610, 1613).
- [47] Raise the axle lift, insert the tongue on the formed plate (1613) into the groove in the hanger bracket (arrow) and align it until all holes line up.



**Repair guide!**  
In the version with a channel cross member, the formed plate is mounted onto the lower flange of the support section from the rear.

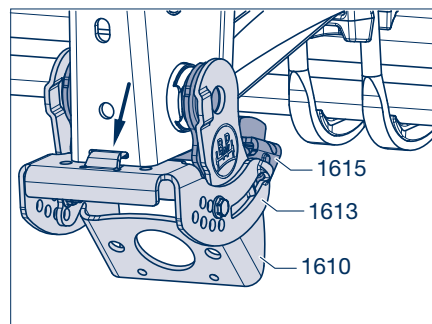

Picture 24

- [48] From one side, insert the mandrel or dis-used spring bolt and in this way position the axle lift.
- [49] Smear spring pivot bolts (1156) with grease.
- [50] Insert the connecting link disc (1161) into the anti-rotation lock of the air suspension hanger (1511).
- [51] Push in the spring bolt to the inside edge of the support bush.

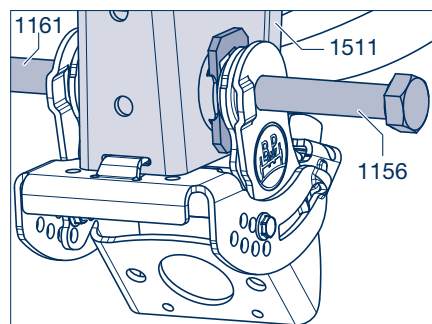

Picture 25

- [52] Mount the loose wearing plate (1525) between the support bush and the trailing arm bushing.
- [53] Insert the spring bolt (1156) and mount the second wearing plate. In doing so, the mandrel or dis-used spring bolt will be forced out of the spring pivot bolt bearing.
- [54] Mount the second adjusting plate (1161). The bevels of the adjusting plates must be aligned with each other and must mesh with the support jaw on both sides.

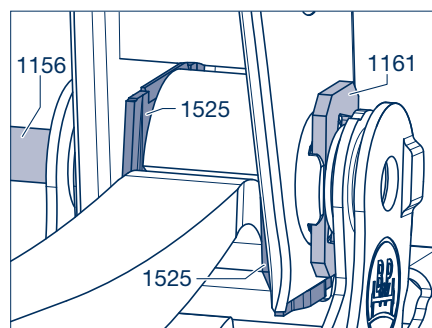

Picture 26

- [55] Fully insert the spring bolt (1156) until the spring bolt head is positioned in the torsion protection on the shaped plate (1610, arrow).

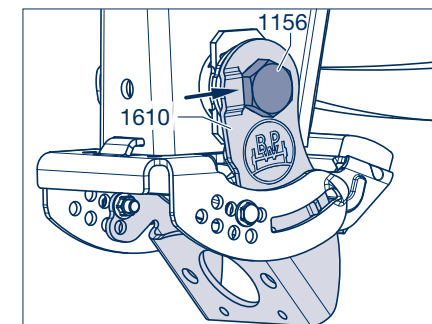

Picture 27

- [56] Depending on the version, place the disc (1165) on the spring bolt (1156).

- [57] Tighten the lock nut (1168 SW 36) to the specified torque.

Tightening torque:  
M 24 (SW 36) M = **650 Nm** (605 - 715 Nm)

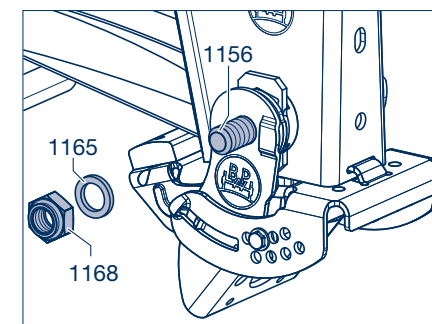

Picture 28

- [58] Mount the lift cylinder (1660) to the shaped plate (1610) with new lock nuts (1663, SW 24 / SW 30) and tighten to a torque of 180 - 210 Nm.

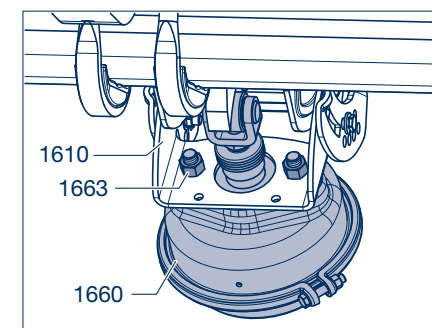

Picture 29

## 13 Dismantling and assembly of axle lift device

### 13.3 Two-side axle lift with fixed and adjustable support, trailing arm 100 mm wide

#### Removal

- [59] Support axle to prevent accidents and deflate air suspension.
- [60] Remove the lifting cylinder (1660), to do this unscrew the two lock nuts (1663, SW 24 / SW 30) from the threaded bolts of the lifting cylinder.

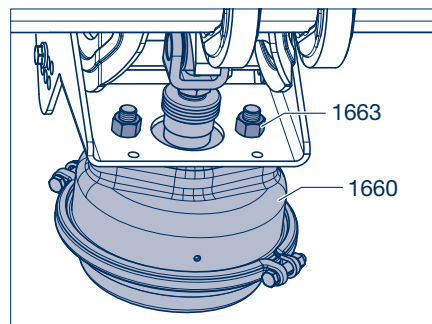

Picture 30

- [61] Remove the upper locking screw (1631, SW 13) from the mounting bracket (1632).

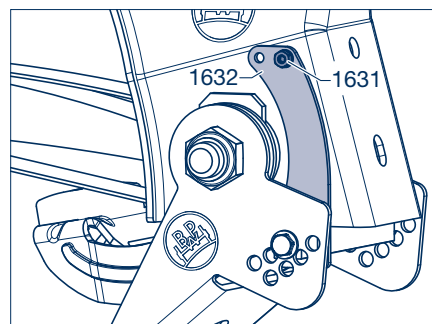

Picture 31

- [62] Unscrew lock nut (1168, SW 46) from spring pivot bolt (1156).

- [63] Push the spring bolt from the bearing.



#### Caution! RISK OF INJURY

To push out the spring bolt, the axle lift is loosened and can fall out with the wearing plates (1525).

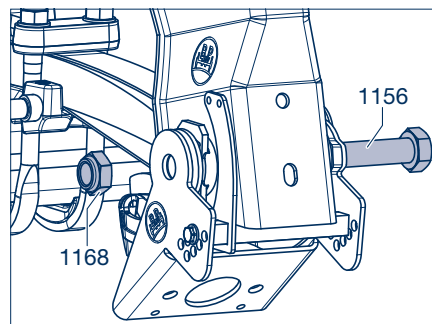

Picture 32

- [64] Remove axle lift with bushes (1175, 1180), adjusting discs (1161) and the wear plates of the supports (1525). (The adjusting plates are not needed for rigid supports.)

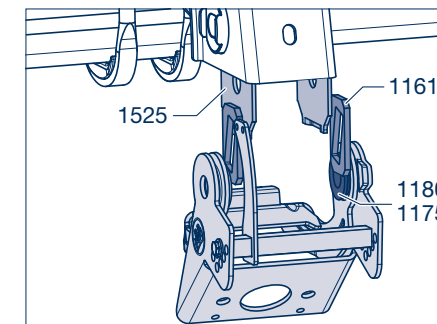

Picture 33

- [65] To replace the bump stop (1620) on the lever (1615), twist the locking nuts (1623, SW 10) of the cylinder head screws (1621).

- [66] Replace the bump stop and mount this on the lever with new cylinder head screws and lock nuts. Tightening torque: 8 Nm

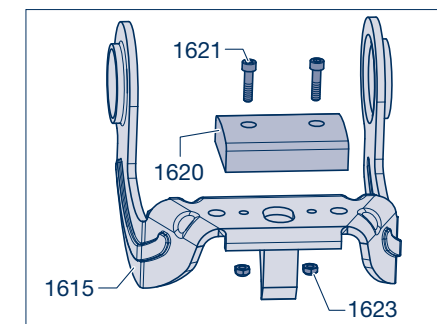

Picture 34

- [67] Note the setting position (arrow) when replacing the bracket (1610, 1611) the square bar (1630) or the plate (1632).

- [68] Remove the locking screws (1635, SW 17).

#### Assembly

-  Clean all parts, check for wear and damage, replace, if necessary.

- [69] If removed, slide the plate (1632) on the square bar (1630).

- [70] Secure the square bar with plate to the bracket (1610, 1611) with new locking screws (1635, SW 17). Use the marked pinning position [step [67]].

Tightening torque: 130 Nm

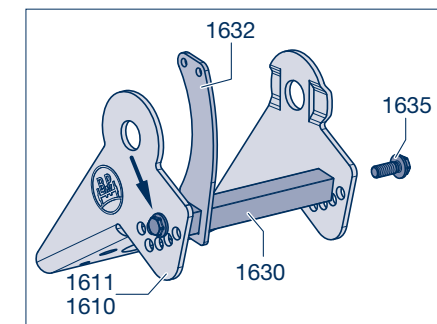

Picture 35

## 13 Dismantling and assembly of axle lift device

- [71] Place the bush (1180) in the correct position on the graduated bush (1175).
- [72] Insert preassembled bushes in the lever (1615) from the inside outwards.

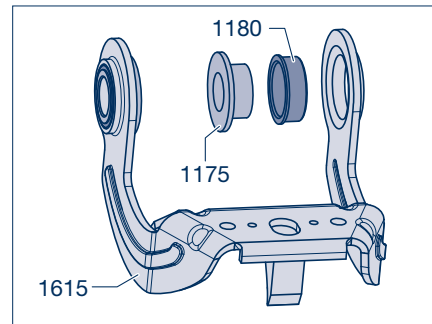

Picture 36

- [73] Prepare a mandrel or dis-used spring bolt.
- [74] Insert the preassembled lever (1615) into the bracket (1610, 1611).
- [75] Raise the axle lift until all bore holes are aligned. The plate (1632) must be located next to the support (1511).
- [76] From one side, insert the mandrel or dis-used spring bolt and in this way position the axle lift.

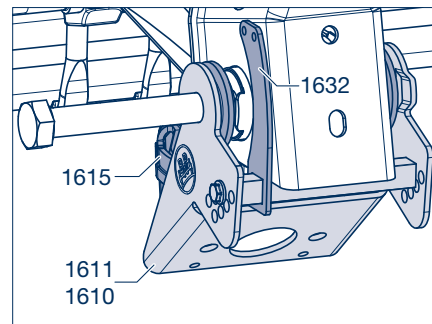

Picture 37

- [77] Grease the spring bolt (1156).
- [78] Insert the adjusting plate (1161) in the torsion protection of the air spring bracket (1511). (The adjusting plates are not needed for rigid supports).
- [79] Push in the spring bolt to the inside edge of the support bush.

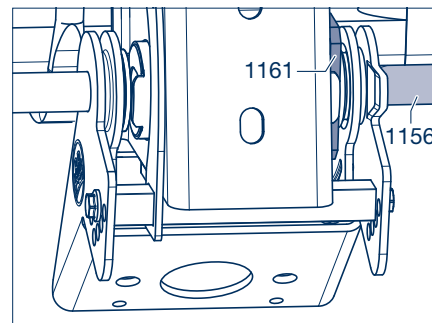

Picture 38

- [80] Mount the loose wearing plate (1525) between the support bush and the trailing arm bushing.
- [81] Insert the spring bolt (1156) and mount the second wearing plate. Here, the mandrel or dis-used spring bolt will be forced out of the spring pivot bolt bearing.

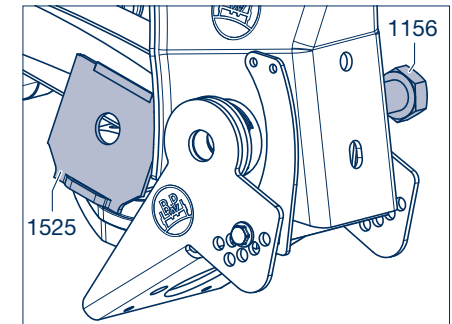

Picture 39

- [82] Mount the second adjusting plate (1161). The bevels of the adjusting plates must be aligned with each other and must mesh with the support jaw on both sides.
- [83] Fully insert the spring bolt (1156) until the spring bolt head is positioned in the torsion protection on the bracket (1610, 1611, arrow).

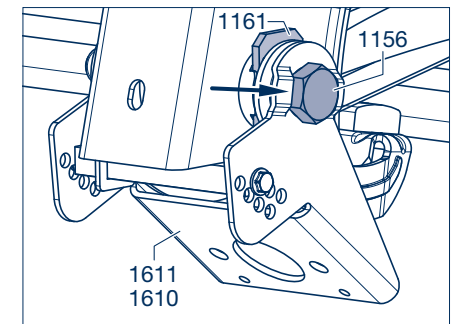

Picture 40

- [84] Unscrew the lock nut (1168, SW 46) and tighten to the specified torque.

Tightening torque:

Hanger brackets from 08/2001:

M 30 (SW 46) M = **900 Nm** (840 - 990 Nm)

Hanger brackets up to 07/2001:

M 30 (SW 46) M = **750 Nm** (700 - 825 Nm)

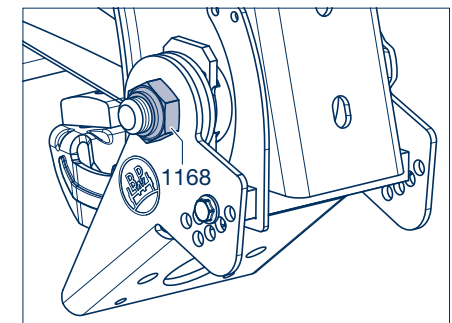

Picture 41

## 13 Dismantling and assembly of axle lift device

- [85] Fit the lift cylinder (1660) to the shaped plate (1610, 1611) with new lock nuts (1663, SW 24 / SW 30) and tighten to a torque of 180 - 210 Nm.

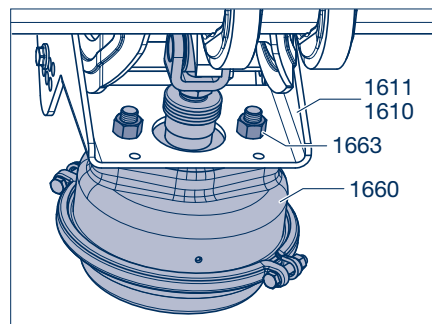

Picture 42

- [86] Press the square bar (1630) on to the support (1511). Ensure there is no play.



### Repair guide!

When using a new support, a bore hole of  $\varnothing$  7.5 mm must be drilled perpendicularly to the support. Here, depending on the tracking position, the front or rear bore hole in the plate (1632) can be used as a drill template.

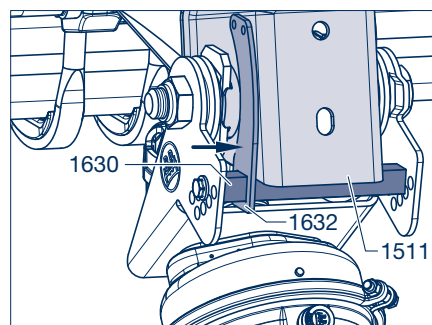

Picture 43

- [87] Secure the plate (1632) to the air spring bracket with a self-tapping locking screw (1631, SW 13).

Tightening torque : 30 Nm

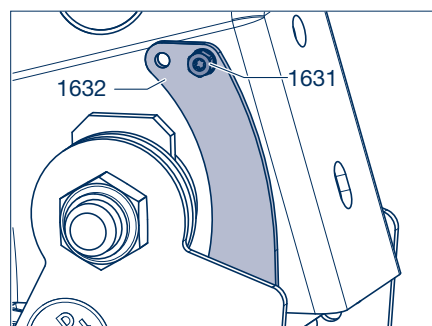

Picture 44

### 13.4 Two-side axle lift with adjustable, bolted support – SLO / SLM series

#### Removal

- [88] Support axle to prevent accidents and release air from air suspension system
- [89] Unscrew the hexagon nut (1571, SW 27) from the mounting screws (1570) of the gusset plate and detach the gusset plate.

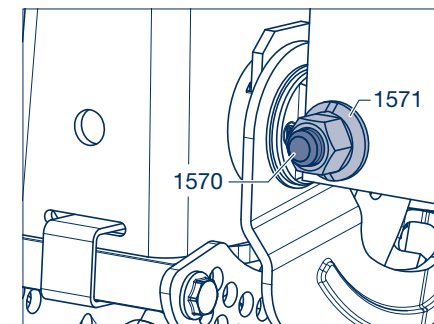

Picture 45

- [90] Remove the lifting cylinder (1660), to do this unscrew the two lock nuts (1663, SW 24 / SW 30) from the threaded bolts of the lifting cylinder.

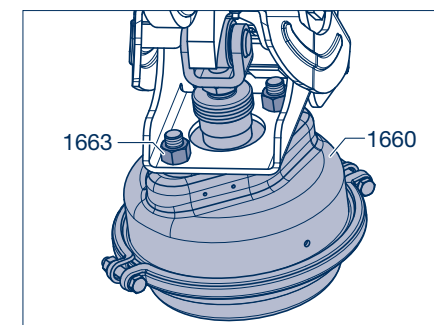

Picture 46

- [91] Unscrew the lock nut (1168, SW 36) from the spring bolt (1155).

- [92] Pull the graduated bush (1180) with the bush (1175) from the spring bolt.

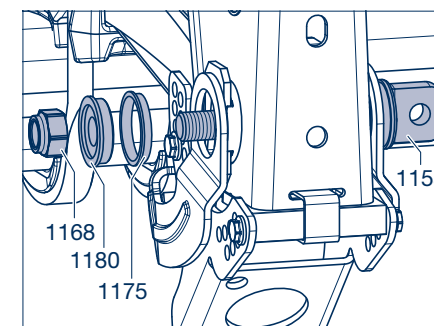

Picture 47

## 13 Dismantling and assembly of axle lift device

- [93] Push the spring bolt (1155) from the bearing and detach with the bush (1175).



**Caution! RISK OF INJURY**  
When the spring bolt is pushed out, the lever (1615) is loosened and can fall out with the wearing plates (1525) and adjusting plates (1161).

- [94] Take off the lever (1615).

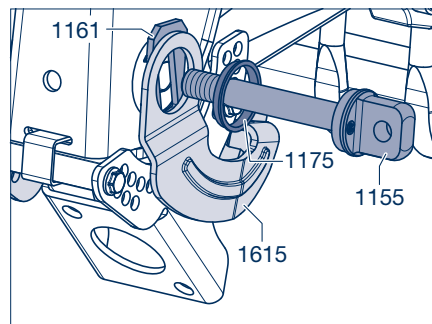

Picture 48

- [95] Before removing the bracket (1610), mark the setting position (arrows) of the locking screws (1635, SW 17).

- [96] Unscrew the lock nuts (1636 SW 17) and remove the two locking screws.

- [97] Pull the bracket forward out of the support and remove.

- [98] If necessary, detach the square bar (1630) by removing the two locking screws (1635, SW 17).

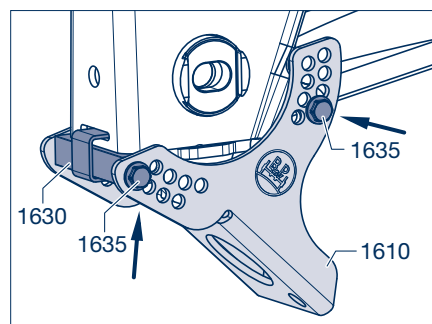

Picture 49

- [99] To replace the bump stop (1620) on the lever (1615), twist the locking nuts (1623, SW 10) of the cylinder head screws (1621).

- [100] Replace the bump stop and mount this on the lever with new cylinder head screws and lock nuts.

Tightening torque: 8 Nm

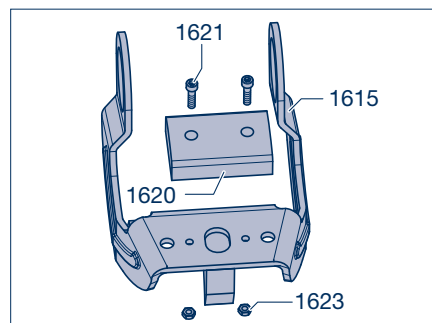

Picture 50

### Assembly

- Clean all parts, check for wear and damage, replace, if necessary.

- [101] Screw the square bar (1630) with two new locking screws (1635, SW 17) to the bracket in the marked setting position (step [95]) (1610); do not tighten.

- [102] From the front, insert the preassembled bracket in the notch of the support (1511).

- [103] Screw in the bracket (1610) onto the support in the marked setting position with two new locking screws (1635, SW 17) and lock nuts (1636).

- [104] Tighten all locking screws (1635) with a torque of 75 Nm.

- [105] Mount the new bushes (1175) in the correct position on the spring bolt (1155) and the graduated bush (1180).

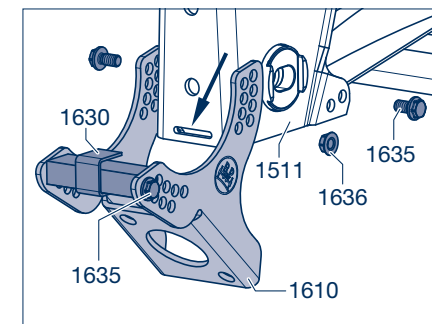

Picture 51

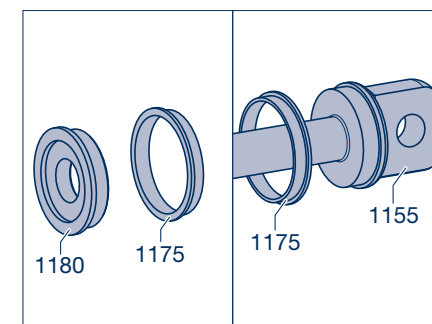

Picture 52

- [106] Prepare a mandrel or dis-used spring bolt.

- [107] Position the lever (1615) on the support in such a way that all bore holes are aligned.

- [108] From the outside, insert the mandrel or dis-used spring bolt and in this way position the lever.

- [109] Grease the spring bolt (1155).

- [110] Insert the adjusting plate (1161) in the torsion protection of the air spring bracket (1511).

- [111] Push in the spring bolt to the inside edge of the support bush.

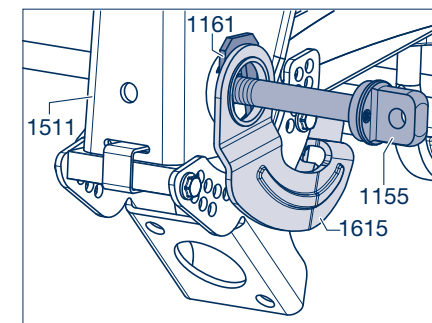

Picture 53

## 13 Dismantling and assembly of axle lift device

[112] Mount the loose wearing plate (1525) between support bush and the trailing arm bushing.

[113] Insert the spring bolt (1155) and mount the second wearing plate. Here, the mandrel or dis-used spring bolt will be forced out of the spring pivot bolt bearing.

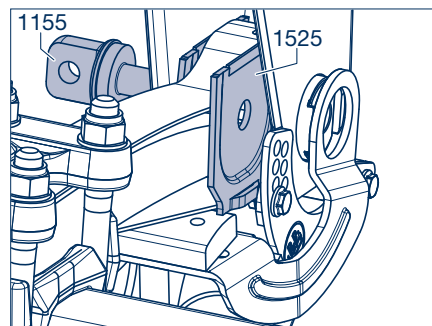

Picture 54

[114] Mount the second adjusting plate (1161). The bevels of the adjusting plates must be aligned with each other and must mesh with the support jaw on both sides.

[115] Fully insert the spring bolt (1155) until it makes contact with the adjusting plate. The bush (1175) is positioned in the seating of the lever (1615).

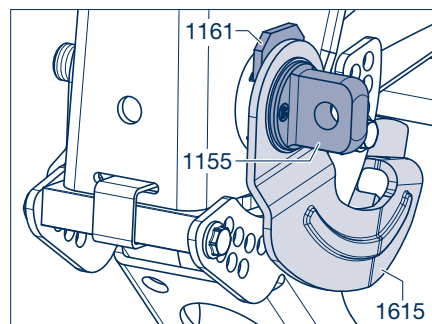

Picture 55

[116] Attach the pre-assembled graduated bush (1180) to the spring bolt (1155) and insert into the seating of the lever (1615).

[117] Unscrew the lock nut (1168, SW 36). Do not tighten.

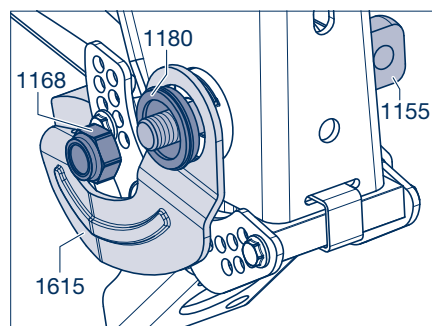

Picture 56

[118] Secure gusset plate with at least 3 screws on top on the crossmember and loosely pre-mount on the spring bolt (1155) with a screw (1570) with lock nut (1571, SW 27) and tighten until it is in contact.

[119] After track setting, tighten the spring bolt (1155, SW 36) with a torque of **650 Nm** (605 - 715 Nm).

[120] Tighten the lock nut (1571) to a torque of **420 Nm** (390 - 460 Nm).

[121] Tighten the upper screws on the crossmember to the specified torque.

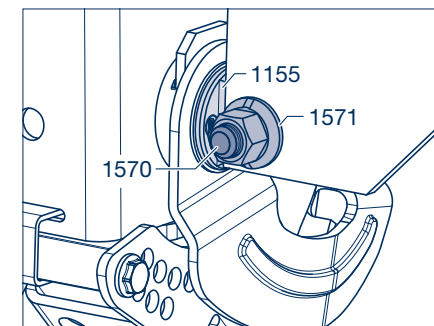

Picture 57

[122] Mount the lift cylinder (1660) to the bracket (1610) with new lock nuts (1663, SW 24 / SW 30) and tighten to a torque of 180 - 210 Nm.

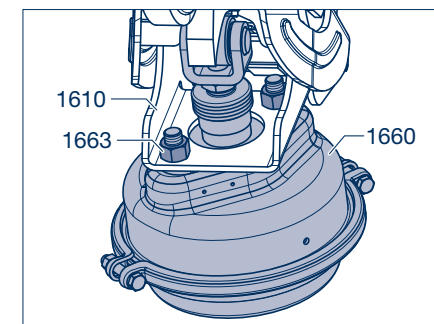

Picture 58

## 14 Air suspension valve

### General

The air suspension valve controls the air bag pressure as a function of vehicle load and keeps the ground clearance at the same level no matter the load condition.

It is attached to the chassis frame by bolts and connected to the axle by a pivot linkage arrangement.

The pivot link is located in the middle of the axle, on three axle units at the centre axle, on two-axle units on the rear axle. In special cases (e.g. axle lift device, large vehicle slope) the air suspension valve may also be connected to the front or rear axle. In exceptional cases two air suspension valves may be fitted.

### Replacing

- [1] Release air from air suspension system.
- [2] Unscrew union nuts of the compressed air lines from the connections at the air suspension valve.
- [3] Unscrew nut from the pivot link at the axle.



**Repair guide!**  
Do not fit and secure nut (2) complete with spring washer (3) until after having adjusted the air suspension valve.

- [4] Unscrew securing bolts of the air suspension valve, remove valve.
- [5] The valve is refitted on in the reverse order. Following this, check compressed air system for leaks.

### Setting

- [6] Fill up compressed air reservoir. Unscrew nut (2) complete with spring washer (3).
- [7] To check operation, move valve lever down slightly. This must cause air to flow through the vent cap to atmosphere. If, however, this causes air to flow into the air bags, the valve shaft must be turned through 180 degrees. The valve lever must be switched over for this purpose.

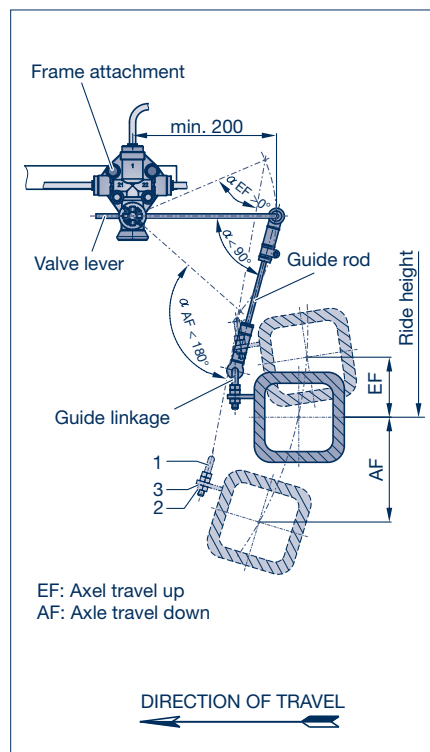

Picture 1

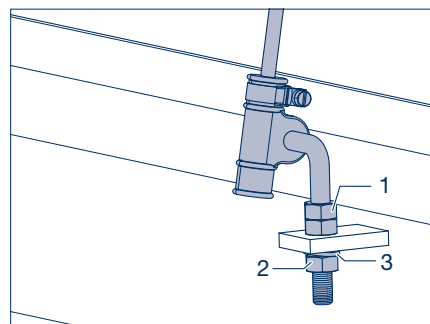

Picture 2

- [8] Check the length of the valve lever; it must be at least 200 mm; if necessary, alter accordingly after slackening the clamping screw (arrow) and re-tighten clamping screw.



**Repair guide!**  
The angles stated (picture 1) must be maintained to avoid the valve linkage going over centre.

- [9] Press valve lever down and hold in this position until the vehicle has fully lowered.
- [10] Slowly push valve lever up and hold until a single-axle vehicle has been raised by at least 60 mm, two- and three-axle vehicles by at least 70 mm and vehicles with axle lift device by at least 100 mm.
- [11] After these setting heights have been reached, the air suspension valve lever must be moved into the horizontal position (picture 1).
- [12] Insert guide linkage (5) into the fastening lug on the axle beam. Screw on nut (2) with spring washer (3).
- [13] Connect valve lever and guide linkage with one another via the guide rod (6). After fitting the valve, lever must be located in the horizontal position. If necessary, re-adjust the double nut (1) correspondingly and tighten the nut (3). Fasten the guide rod by tightening the screws on the band clamps.

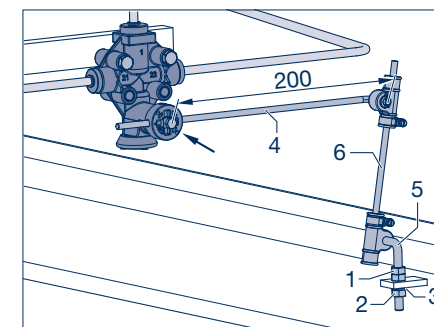

Picture 3

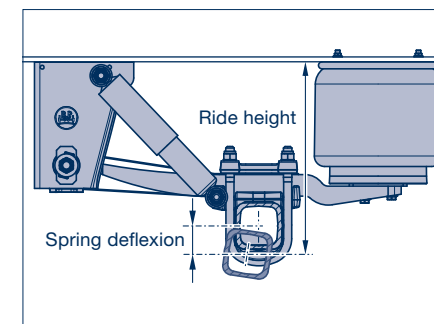

Picture 4

### Spring deflection

Single axles:	60 mm
Tandem / Triaxle:	70 mm
with axle lift:	100 mm



## 15 Shut-off valve

### General

A stroke limitation may be required in air suspension systems with a lifting and lowering device depending on the manufacturer's information!

The stroke limiter may be in the form of a shut-off valve. The shut-off valve is bolted to the vehicle frame and connected to the axle by a tension spring attached to the tension pin. After the maximum lift height is reached, the air supply to the air bag is shut off and the travel thus limited.

 The stroke limiter can also take the form of an air levelling valve with integrated shut-off.

### Replacing

- [1] Release air from air suspension system.
- [2] Unscrew union nuts of the compressed air lines from the connection at the shut-off valve.
- [3] Unscrew union nuts of the compressed air lines from the connection at the shut-off valve.
- [4] Bolt on new shut-off valve, insert tension spring into the hole of the stop on the axle, attach tension spring in shut-off valve and connect compressed air lines.
- [5] Fill up compressed air reservoir and check connections for leaks.
- [6] Raise vehicle to maximum lift height.
- [7] In this position, bend over the bottom end of the tension spring (arrow) so that the bent part is resting against the stop. A clamp-type screw connection can also be used as a stop.
- [8] Lower vehicle to normal ride height.

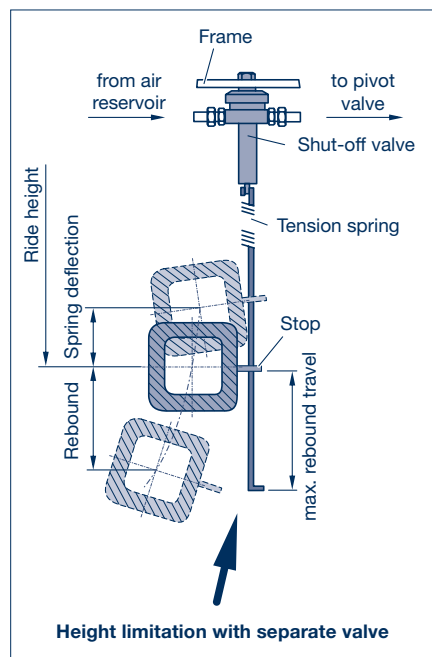

Picture 1

## Axle alignment check 16

 **Repair guide:**  
Begin measurements on tandem-axle vehicles at the front axle and on tri-axle vehicles at the centre axle (reference axle).

 **Repair guide:**  
In the case of suspensions with a self-steered axle, engage the steering lock. Zero position of the steering turntable is absolutely essential.

 **Note:**  
For units with new hub caps (embossed ®, ECO or ECO Plus under the BPW logo) (Picture 1), as well as for ECO Plus 3, only the hub caps need to be unscrewed from the reference axle.

### 16.1 Conventional axle alignment check on the vehicle

- [1] For older hub caps as shown in Picture 1, unscrew the hub caps and remove the grease on the wheel hubs.



Picture 1

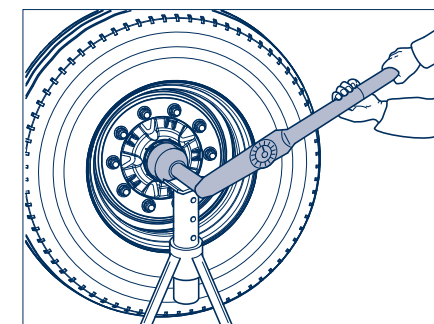

Picture 2

- [2] Screw threaded adapters (1) (BPW number see chapter 2) onto the wheel hubs of the reference axle, screw in both aligning tubes (picture 2) and raise the reference axle far enough until both wheels are clear of the ground.

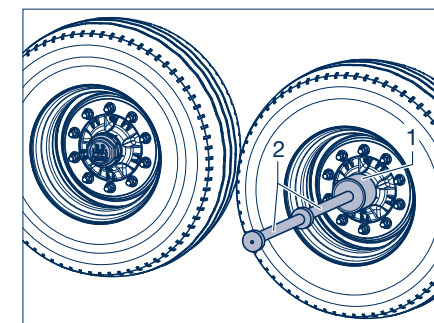

Picture 3

## 16 Axle alignment check

- [3] With the wheel rotating freely, determine the high-est point of the runout at the alignment tubes (with parallel marking tool) and turn until it is at the top. Lower axle onto the ground.



**Note:**  
If no parallel marking tool is available, the runout of the aligning tubes can also be marked with a piece of chalk; place a piece of wood or similar on the ground for this purpose. Turn wheel and then mark the highest point of the runout with chalk.

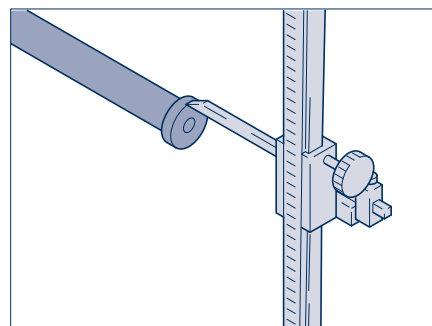

Picture 4

- [4] Determine the diagonal dimensions A-B and A-C for the reference axle by taking comparison measurements (tolerance  $\pm 2$  mm).

- [5] If the tolerance is exceeded, the axle must be aligned under the vehicle.

Adjustable supports, see page 100.

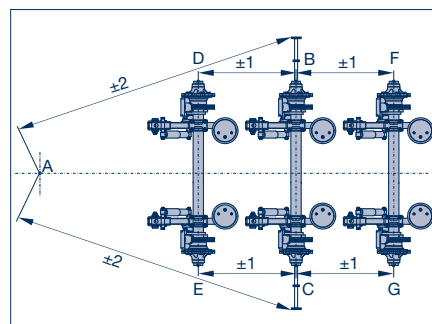

Picture 5

### Fixed hanger brackets

- [6] To adjust to correct alignment, slacken U-bolt (1050) and align axle by moving.

- [7] If tracking plates (1041) are fitted, grind off weld seam (arrows) and align axle.

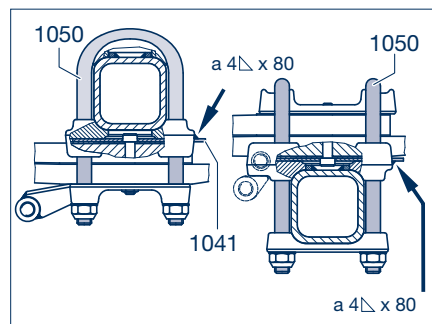

Picture 6

- [8] For each U-bolt (1050) / hexagon screw (1053), always evenly tighten the locknuts (1057, SW 32) (1330, SW 36) – until all parts are in uniform contact. (The axle spring seats (1026, 1027) and segments (1035) should rest just within the radii of the axle beam (arrows).



**Repair guide!**  
Do not introduce uneven tension by using an incorrect tightening sequence.

- [9] Tighten the lock nuts (1057, SW 32) (1330, SW 36) reciprocally in several stages with a torque wrench in the order 1-2-3-4 (crosswise). Ensure the amount of thread below the U-bolt lock nuts is the same!

Tightening torque with a torque wrench:

M 20 (SW 30)	M = 340 Nm (315 - 375 Nm)
M 22 (SW 32)	M = 550 Nm (510 - 605 Nm)
M 24 (SW 36)	M = 650 Nm (605 - 715 Nm)

AL II with new spring mounting kit components:

Tighten all lock nuts (SW 32) to a tightening torque of 200 Nm, then to 300 Nm, 450 Nm and 550 Nm. As the last step, turn all lock nuts through a further 90°.

- [10] Re-weld tracking plates (if fitted) to the spring pads (picture 6 / arrows).



**Repair guide!**  
Weld the tracking plate with a weld seam of a 4 x 80 mm.

- Mount caps for new hub caps (embossed ©, ECO or ECO Plus under the BPW symbol, as well as ECO Plus 3); see step [13].

- The triangle ( $\Delta$ ) in the BPW symbol is centred if a ©, ECO or ECO Plus is embossed under the BPW symbol or if an ECO Plus 3 cap is being used.

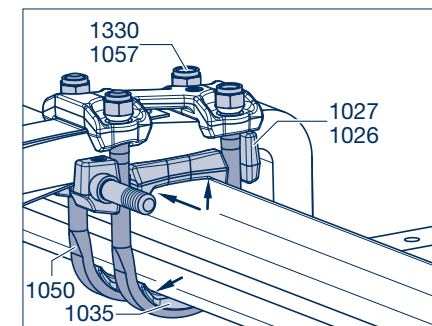

Picture 7

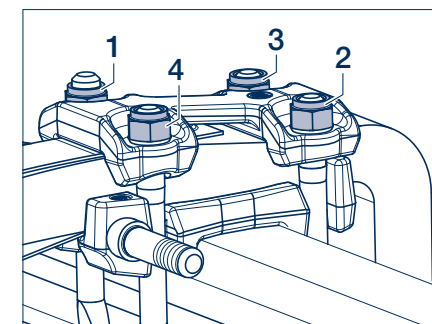

Picture 8



Bild 9

## 16 Axle alignment check

- [11] Measure distance from the reference axle to the nearest axles using the triangle in the centre of the hub caps or, in the case of old hub caps, in the recesses of the steering knuckles; permissible tolerance  $\pm 1$  mm (page 98, picture 5).
- [12] If differences exist in the results of the measurement, perform adjustments as described in steps [6] to [10].
- [13] If required, refill hub caps with some BPW ECO-Li<sup>Plus</sup> special longlife grease (not required with ECO and ECO Plus Unit) and mount to the specified torque; see cap embossing.

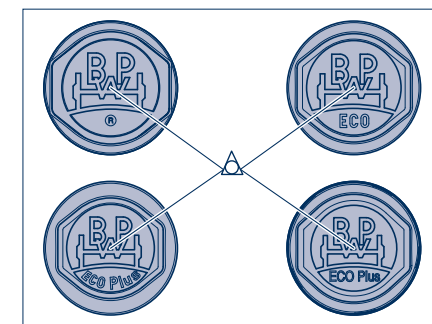
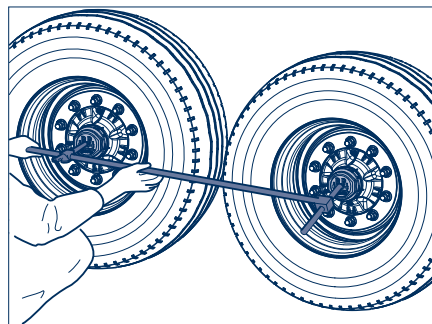

Picture 10

### Adjustable hanger brackets

- [14] To correct, slacken the lock nuts (1168, SW 36 / SW 46) on the spring pivot bolt (1154) slightly and uniformly slide the connecting linkage (1161) on both sides, either upwards on the tracking-in direction, upwards or downwards with light hammer blows (picture 11 and 12).
- [15] After correction, tighten lock nut to the specified torque.

Tightening torques with a torque wrench:

Air suspension hanger brackets and channel crossmember Airlight II from 09/2007:  
M 24 (SW 36) M = **650 Nm** (605 - 715 Nm)

Hanger brackets from 08/2001:  
M 30 (SW 46) M = **900 Nm** (840 - 990 Nm)

Hanger brackets up to 07/2001:  
M 30 (SW 46) M = **750 Nm** (700 - 825 Nm)

Channel crossmember:  
M 30 (SW 46) M = **900 Nm** (840 - 990 Nm)

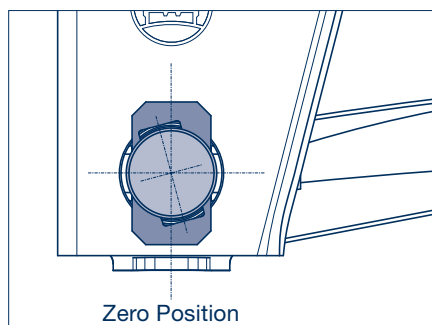

Picture 11

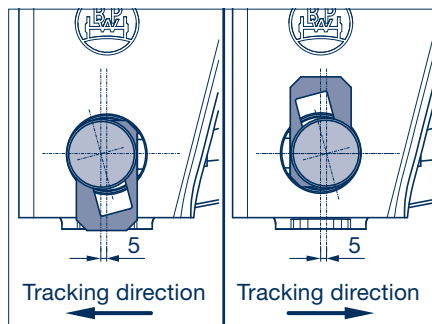

Picture 12

- [16] If required, refill hub caps with some BPW ECO-Li<sup>Plus</sup> special longlife grease (not required with ECO and ECO Plus Unit) and mount to the specified torque; see cap embossing.
- The triangle ( $\Delta$ ) in the BPW symbol is centred if a  $\text{\textcircled{R}}$ , ECO or ECO<sup>Plus</sup> is embossed under the BPW symbol or if an ECO Plus 3 cap is being used.

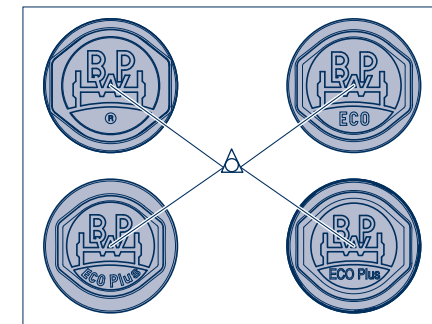

Picture 13

- [17] Measure distance from the reference axle to the nearest axles using the triangle in the centre of the hub caps (picture 13) or, in the case of old hub caps, in the recesses of the steering knuckles; permissible tolerance  $\pm 1$  mm (page 98, picture 5).
- [18] If differences exist in the results of the measurement, perform adjustments as described in steps [14] to [16].

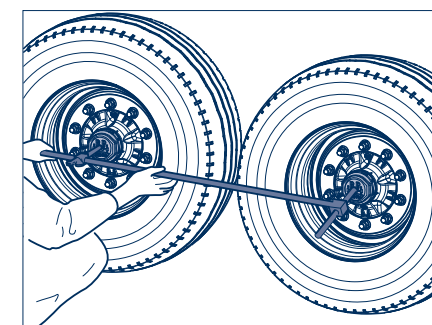

Picture 14

## 16 Axle alignment check

### 16.2 Axle alignment check with laser measuring devices

- [19] Set up the laser in accordance with the manufacturer's instructions. Make sure the axle is positioned horizontally, in order to avoid camber values falsifying the measuring results.

Calculating the toe values:

$$\text{Toe} = \frac{A1 - B1 \text{ (mm)}}{A \text{ (m)}} \quad \begin{array}{l} \text{Positive value} = \text{Toe-in} \\ \text{Negative value} = \text{Toe-out} \end{array}$$

- [20] Perform the measurement on both sides and add together the measurement values. The total of the values is the toe-in/toe-out value of the axle and must be within the permitted tolerance range.

Permitted toe tolerance range per axle:

for rigid axles: -1 to +5 mm/m

for LL axles

unladen: -2 to +2 mm/m

laden: 0 to +6 mm/m

- [21] If the values are outside tolerance, correct the toe (see chapter 16.1).

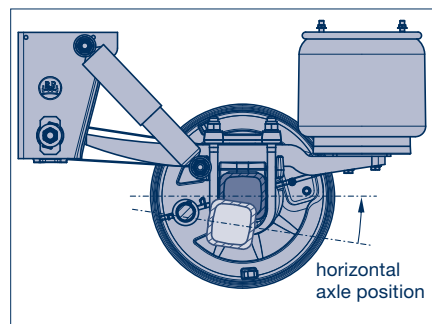

Picture 15

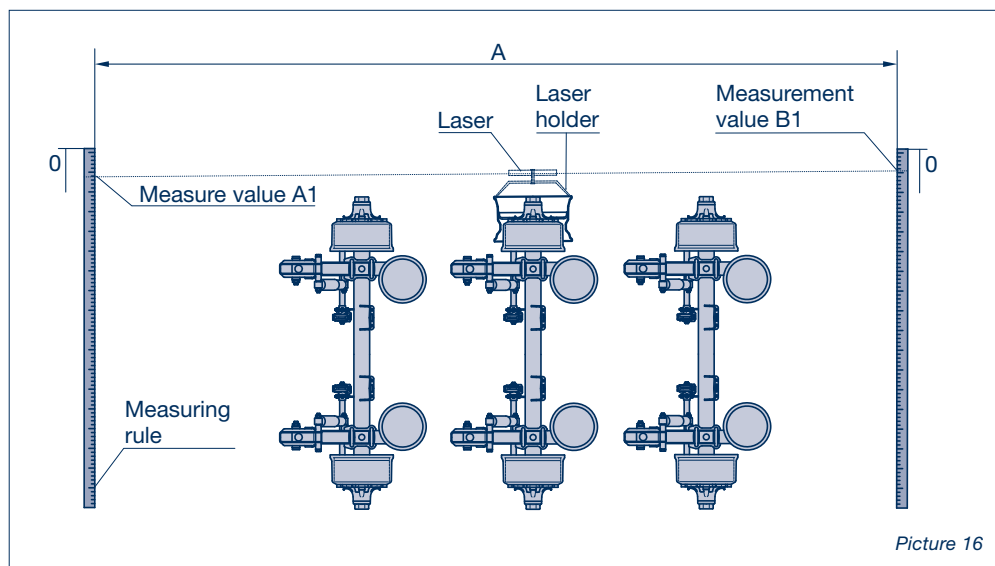

Picture 16

- [1] Check the compressed air and brake systems for leaks.
- [2] Tighten all nuts and bolts to the specified torque, see chapter 4.
- [3] Check clearances at moving parts.
- [4] Ensure that the check straps, if fitted, do not chafe on air bags, axle beam and brake camshafts.

## Other inspection operations 17



BPW-WH-AL-SL-O 3539170 1e

BPW is a globally leading manufacturer of intelligent running gear systems for trailers and semi-trailers. As an international mobility and system partner, we offer a wide range of solutions for the transport industry from a single source, from axle to suspension and brake to user-friendly telematics applications.

We thereby ensure outstanding transparency in loading and transport processes and facilitate efficient fleet management. Today, the well-established brand represents an international corporation with a wide product and service portfolio for the commercial vehicle industry. Offering running gear systems, telematics, lighting systems, composite solutions and trailer superstructures, BPW is the right system partner for automotive manufacturers.

BPW, the owner-operated company, consistently pursues one target: To always give you exactly the solution which will pay off. To this end, we focus our attention on uncompromising quality for high reliability and service life, weight and time-saving concepts for low operating and maintenance costs as well as personal customer service and a close-knit service network for quick and direct support. You can be sure that with your international mobility partner BPW, you always use the most efficient method.

# Your partner on the path to economic viability



**BPW Bergische Achsen Kommanditgesellschaft**

Postbox 12 80 · 51656 Wiehl, Germany · Phone +49 (0) 2262 78-0  
info@bpw.de · [www.bpw.de](http://www.bpw.de)